 IAPMO R & T Certified
against NSF/ANSI 44
and CSA B483.1

89UF/DF Series* Water Softener

***Check the valve sticker
to make sure its UF (Upflow) or
DF (Downflow)**

- 1. Page 25 of this manual contains important maintenance procedures for the continued proper operation of your unit. These MUST be performed regularly for your warranty to remain valid.**
- 2. Read all instructions carefully before operation.**
- 3. Avoid pinched o-rings during installation by applying NSF certified lubricant to all seals (provided with install kit).**
- 4. This system is not intended for treating water that is microbiologically unsafe or of unknown quality without adequate disinfection before or after the system.**

Canada West 855 Park St., Unit 1 Regina, SK S4N 6M1	Canada East 490 Pinebush Rd., Unit 1 Cambridge, ON N1T 0A5	U.S.A. 56 Lightcap Rd. Pottstown, PA 19464	9760 Mayflower Park Drive, Suite 110 Carmel, IN 46032	4655 McDowell Rd. W Phoenix, AZ 85035
--	---	---	---	--

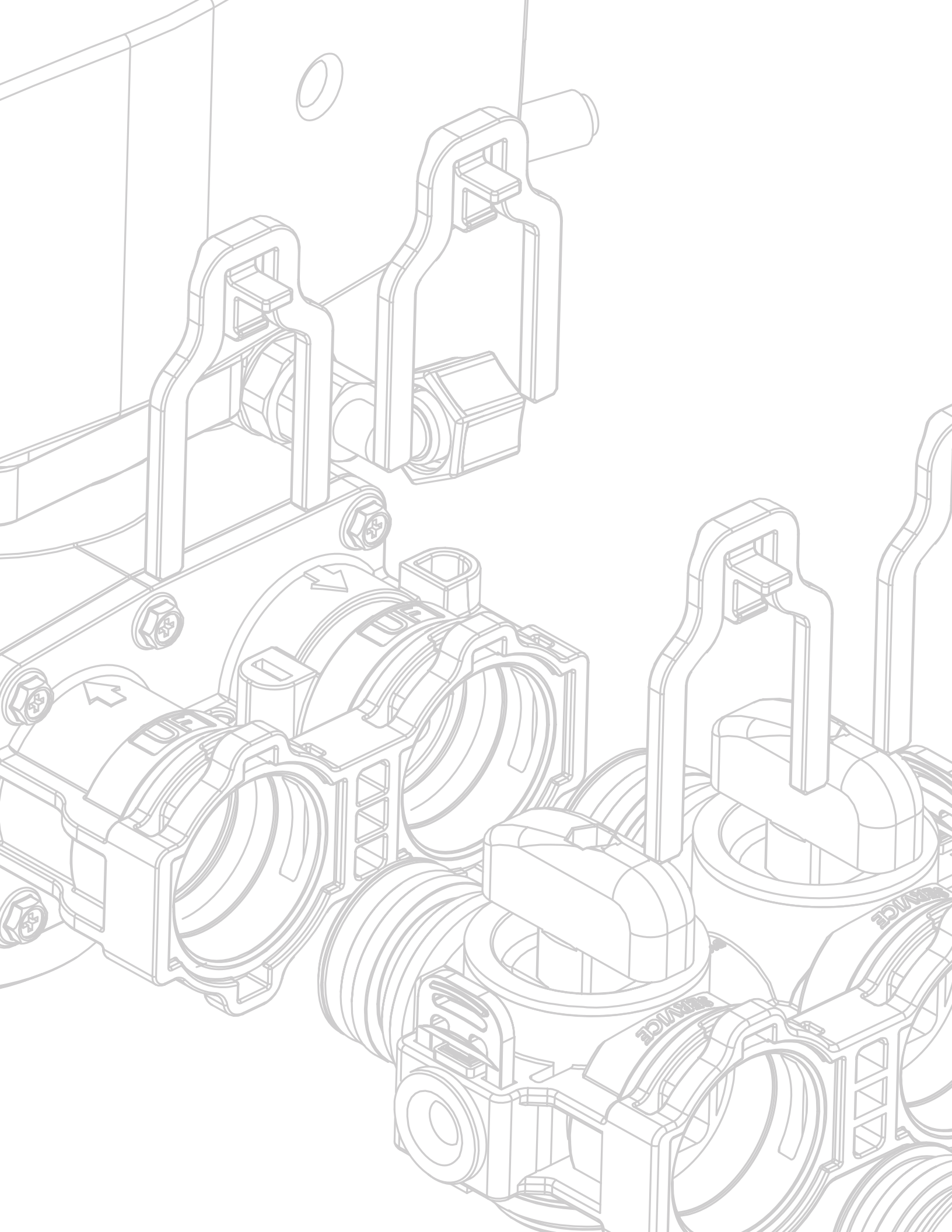

Table of Contents

READ THIS PAGE FIRST BEFORE STARTING INSTALLATION	4
EFFICIENCY STATEMENT	5
HOW YOUR WATER CONDITIONER WORKS	5
SPECIFICATIONS	
SPECIFICATION	6
SYSTEM DIMENSIONS	7
BRINE TANK DIMENSIONS	8
INSTALLATION	
UNPACKING / INSPECTION OF TWIN TANK MODEL	10
UNPACKING / INSPECTION OF CABINET MODEL	12
CHECK VALVE TYPE AND VALVE SERIAL #	13
BEFORE INSTALLATION	14
PREPARATIONS	15
INSTALLATION STEPS	16
INSTALLING BRINE TANK	18
WATER SOFTENER INSTALLATION - UPFLOW	19
WATER SOFTENER INSTALLATION - DOWNFLOW	20
CABINET WATER SOFTENER INSTALLATION - UPFLOW	21
CABINET WATER SOFTENER INSTALLATION - DOWNFLOW	22
STARTUP & PROGRAMMING	23
PLUMBING SYSTEM CLEAN-UP	25
MAINTENANCE INSTRUCTIONS AND SCHEDULE	26
RES-UP® FEEDER INSTALLATION INSTRUCTIONS	27
SERVICING 89HE VALVE	29
TROUBLE SHOOTING GUIDE	30
REPLACEMENT	
TIMER REPLACEMENT	32
PISTON AND/OR BRINE VALVE ASSEMBLY REPLACEMENT	32
METER ASSEMBLY REPLACEMENT	33
REPLACING THE BYPASS AND METER CABLE	34
CLEAN INJECTOR ASSEMBLY	35
REPLACE MOTOR	35
REPLACE MICROSWITCHES	35
CIRCUIT BOARD REPLACEMENT	36
REPLACE BRINE LINE FLOW CONTROL	36
REPLACE DRAIN LINE FLOW CONTROL	36
AFTER SERVICING	37
PARTS BREAKDOWN	37
PARTS	
POWERHEAD / BYPASS	39
VALVE BODY	40
DLFC PART # FOR 89 VALVE / BLFC PART # FOR 89 VALVE	
/INJECTOR PART # FOR 89 VALVE	41
CABINET	42
MASTER PROGRAMMING	43
IMPORTANT WARRANTY AND MAINTENANCE INFORMATION	51

READ THIS PAGE FIRST

BEFORE STARTING INSTALLATION

- ▶ Read this manual thoroughly to become familiar with the appliance and its capabilities before installing or operating the new appliance. Failure to follow instructions in this manual could result in personal injury or property damage. This manual will also help you to get the most out of your new appliance.
- ▶ Installation must comply with all State, provincial or local regulations. Check with your local public works department for plumbing and sanitation codes. In the event the codes conflict with any content in this manual the local codes should be followed. Consult your licensed plumber for installation of this system.
- ▶ **WARNING!** Do not use water that is microbiologically unsafe without adequate disinfection before or after this system.
- ▶ This appliance is designed to operate on pressures of 30 psi to 125 psi. If the water pressure is higher than the maximum use a pressure reducing valve in the water supply line to the device.
- ▶ This appliance is capable of operating at temperatures between 40°F and 110°F (4°C - 43°C). Do not use this appliance on hot water supplies.
- ▶ Avoid pinched o-rings during installation by applying (provided with install kit) NSF certified lubricant to all seals.
- ▶ It is not uncommon for sediment, precipitated iron or hardness to be present in water supplies. Precipitated minerals or sediments can cause damage to the seals and piston. This is considered a harsh environment and the seals and piston would not be covered by warranty stated or otherwise.
- ▶ It is recommended to regularly inspect and service the control valve on an annual basis. Cleaning and or replacement of piston, seals, and or spacers may be necessary depending on how harsh the conditions are. An Annual Maintenance kit is available for this purpose
- ▶ This publication is based on information available when approved for printing. Continuing design refinement could cause changes that may not be included in this publication. The manufacturer reserves the right to change the specifications referred to in this literature at any time, without prior notice.

INSTALL NOTES & SAFETY MESSAGES

Watch for the following messages in this manual:

NOTE

Do not remove or destroy the serial number. It must be referenced on request for warranty repair or replacement

NOTE: used to emphasize installation, operation or maintenance information which is important but does not present a hazard.

CAUTION!

Disassembly while under pressure can result in flooding.

CAUTION: used when failure to follow directions could result in damage to equipment or property.

WARNING!

ELECTRICAL SHOCK HAZARD! UNPLUG THE UNIT BEFORE REMOVING THE COVER OR ACCESSING ANY INTERNAL CONTROL PARTS

WARNING: used to indicate a hazard which could cause injury or death if ignored.

EFFICIENCY STATEMENT

This product is efficiency rated according to NSF/ANSI 44. The stated efficiencies are valid only at the specified salt dosages and maximum service flow rate.

PERFORMANCE DATA SHEET

Model Number	89HE-75C	89HE-100C	89HE-75	89HE-100	89HE-150	89HE-200	89HE-300
Qty High Capacity Resin	0.75 ft ³	1.0 ft ³	0.75 ft ³	1.0 ft ³	1.5 ft ³	2.0 ft ³	3.0 ft ³
Rated Service Flow (gpm)	7.5	12.1	7.5	11.0	11.2	12.4	12.9
Pressure Drop at Rated Service Flow (psi)	7.0	15.0	9.0	15.0	15.0	15.0	15.0
Rated Softening Capacity (grains)	9,609 @ 2.25lbs	13,269 @ 3lbs	10,222 @ 3lbs	13,269 @ 3lbs	20,443 @ 4.5lbs	27,258 @ 6lbs	40,887 @ 9lbs
Efficiency (grains/lb salt)	4,271	4,543	4,543	4,543	4,543	4,543	4,543
Max. Flow Rate to Drain (gpm)	2.0	2.4	1.5	2.0	2.4	3.5	5.0
Working Pressure	Min. 20 - Max. 125 psi						
Operating Temperature	Min 39 - Max. 100 degrees Fahrenheit						

These softeners conform to NSF/ANSI 44 for the specific performance claims as verified and substantiated by test data. These models are efficiency rated. The efficiency rating is valid only at the stated salt dose and maximum service flow rate. They have a demand initiated regeneration (D.I.R.) feature that complies with specific performance specifications intended to minimize the amount of regenerant brine and water used in their operation. These softeners have a rated softener efficiency of not less than 3350 grains of total hardness exchange per pound of salt (based on sodium chloride) and shall not deliver more salt than their listed ratings. The rated salt efficiency is measured by laboratory tests described in NSF/ANSI Standard 44. These tests represent the maximum possible efficiency that the systems can achieve. Operational efficiency is the actual efficiency after the system has been installed. It is typically less than the efficiency due to individual application factors including water hardness, water usage, and other contaminants that reduce the softener's capacity. These systems are not intended for use with water that is microbiologically unsafe or of unknown quality without adequate disinfection before or after the system. For best results, use plain, white block salt. Refer to Installation/operation manual and warranty for further details on installation, parts and service, maintenance and further restrictions or limitations to the use of the product.

HOW YOUR WATER CONDITIONER WORKS

Water softeners remove hardness in the water by exchanging particles in the water, or ions. They remove hard ions such as calcium and magnesium in the water by trading it for sodium ions producing soft water. Unlike the calcium and magnesium, sodium stays dissolved in water and does not form a scale. Sodium also does not interfere with the cleaning action of soaps. The sodium is released by a charged resin contained in the softener, this resin also traps the calcium and magnesium ions. Eventually this resin releases all of its sodium and has filled up with other ions, so it then must be regenerated. Regeneration is accomplished by washing the resin with a salt saturated brine solution that removes the calcium and magnesium while replenishing the sodium. This is why the softener requires a brine tank and salt. The water softener can run for days before running out of sodium, and when it does, the sodium is replenished in only a matter of a few hours

When using a softener to remove both hardness and dissolved iron it is important that it regenerates more frequently than ordinarily would be calculated for hardness removal alone. Although many factors and formulas have been used to determine this frequency, it is recommended that the softener be regenerated when it has reached 50–75% of the calculated hardness alone capacity. This will minimize the potential for bed fouling.

If you are operating a water softener on clear water iron, regular resin bed cleaning is needed to keep the bed from coating with iron. Even when operating a softener on water with less than the maximum of dissolved iron, regular cleanings should be performed. Clean every six months or more often if iron appears in your conditioned water supply. Use resin bed cleaning compounds carefully following the directions on the container.

Precision Brining: Precision brining means that your conditioner calculates the exact amount of brine required to regenerate saving up to 30% more salt

When your conditioner regenerates it will display 2 numbers for capacity 1 will be total capacity the other will be 70 % of capacity. The unit counts down to the end of the 70% then calculates how much of the 30% you used (your reserve) it then adjusts the brine amount accordingly and regenerates that evening. This feature means that your capacity will always be different after every regeneration therefore maximizing your salt use.

BRINE PRE-FILL% : This is the percentage of the water that will be added to the brine tank after a regeneration. The default is 70%. The remaining amount of water will be added just prior to the regeneration and will be proportional to the amount of capacity left in the system.

Soft Water Recharge for High Usage: Should you reach the 70% capacity and then go beyond the 30% before it is time to regenerate the conditioner will do a quick regeneration to restore limited capacity to get it through the remainder of the day.

System Refresh: If you are away for an extended period of time the Conditioner does a refresh cycle to prevent any chance of bacterial growth or stagnation inside the conditioner.

Scrolling Diagnostics: By pressing any button to light the LCD display the unit will automatically begin scrolling important information for diagnostic purposes

Date and Time

Total Gallons and Remaining Gallons

Number of People: in the household as programmed at install

Reserve Capacity: calculated as 75 gallons per person

Estimated Days to Next: estimation of days to the next regeneration based on current consumption, hardness and capacity

Last Regeneration: the date of the last regeneration cycle by the conditioner

Total Regenerations: this is the total number of times the conditioner has regenerated

Total Gallons: total gallons treated by the conditioner

Over Run Total: – how many times Soft water recharge was required due to high usage

Current Flow Rate: will only display if treated water is running otherwise it would read 0

Peak Flow: maximum flow that has gone through the conditioner.

Delayed Regen OFF: – generally only used after servicing.

Regen Time: This is the time of day that the conditioner is scheduled to regenerate

Refill Time: The current calculated refill time for makeup brine (displays up to 70% of total brine required)

Valve Mode: current valve setting EG. Softener UF (up flow)

To stop the scrolling you can unlock the board as directed and press the down arrow to stop the scrolling. You can then use the down arrow to go to each of the diagnostics as required.



SPECIFICATION

Upflow Softener Models

Model	System Capacity Grains			Flow Rate		Regeneration Water Usage (Gallons)		Mineral Tank Size	Resin Cu. Ft.	Brine Tank / Cabinet Size Inches	Salt Capacity (Lbs)	Ship Weight (Lbs)
	@ 10 lbs/cu ft	@ 6 lbs/cu ft (Factory Setting)	@ 3 lbs/cu ft	Service USGPM	Backwash USGPM	Clean Water (Factory Setting)	Problem Water					
89UF-75	22,500	18,750	11,250	8.0	1.5	34.0	49.6	8 x 44	0.75	BTS 15.0"x34.7"/BTR 18.1x34.7	BTS 230 / BTR 270	93
89UF-100	30,000	25,000	15,000	10.0	2.0	43.4	64.3	9 x 48	1.00	BTS 15.0"x34.7"/BTR 18.1x34.7	BTS 230 / BTR 270	110
89UF-150	45,000	37,500	22,500	12.0	2.4	62.7	90.3	10 x 54	1.50	BTS 15.0"x34.7"/BTR 18.1x34.7	BTS 230 / BTR 270	141
89UF-200	60,000	50,000	30,000	15.0	3.5	87.1	124.6	12 x 52	2.00	20.3 x 37.4	385	158
89UF-250	75,000	62,500	37,500	15.0	4.0	108.9	155.8	13 X 54	2.50	20.3 x 37.4	385	198
89UF-300	90,000	75,000	45,000	15.0	5.0	139.2	196.2	14 x 65	3.00	23.0 x 40.5	550	244
89UF-75C	22,500	18,750	11,250	8.0	2.0	40.5	56.1	9 x 35	0.75	13.8 x 23.6 x 43.3	225	93
89UF-100C	30,000	25,000	15,000	10.0	2.4	48.6	69.5	10 x 35	1.00	13.8 x 23.6 x 43.3	225	110

Downflow Softener Models

Model	System Capacity Grains			Flow Rate		Regeneration Water Usage (Gallons)		Mineral Tank Size	Resin Cu. Ft.	Brine Tank / Cabinet Size Inches	Salt Capacity (Lbs)	Ship Weight (Lbs)
	@ 10 lbs/cu ft	@ 6 lbs/cu ft (Factory Setting)	@ 3 lbs/cu ft	Service USGPM	Backwash USGPM	Clean Water (Factory Setting)	Problem Water					
89DF-75	22,500	18,750	11,250	8.0	1.5	34.0	49.6	8 x 44	0.75	BTS 15.0"x34.7"/BTR 18.1x34.7	BTS 230 / BTR 270	93
89DF-100	30,000	25,000	15,000	10.0	2.0	43.4	64.3	9 x 48	1.00	BTS 15.0"x34.7"/BTR 18.1x34.7	BTS 230 / BTR 270	110
89DF-150	45,000	37,500	22,500	12.0	2.4	62.7	90.3	10 x 54	1.50	BTS 15.0"x34.7"/BTR 18.1x34.7	BTS 230 / BTR 270	141
89DF-200	60,000	50,000	30,000	15.0	3.5	87.1	124.6	12 x 52	2.00	20.3 x 37.4	385	158
89DF-250	75,000	62,500	37,500	15.0	4.0	108.9	155.8	13 X 54	2.50	20.3 x 37.4	385	198
89DF-300	90,000	75,000	45,000	15.0	5.0	139.2	196.2	14 x 65	3.00	23.0 x 40.5	550	244
89DF-75C	22,500	18,750	11,250	8.0	2.0	40.5	56.1	9 x 35	0.75	13.8 x 23.6 x 43.3	225	93
89DF-100C	30,000	25,000	15,000	10.0	2.4	48.6	69.5	10 x 35	1.00	13.8 x 23.6 x 43.3	225	110

*Choose **HIGH EFFICIENCY** to minimize salt usage. Your system will regenerate a little more often but your salt usage can be reduced by 20% compared to the **STANDARD** setting. Choose **STANDARD** when you need to maximize your capacity but still operate the system with good efficiency. Choose ****IRON & MN** if you have problem water containing Iron, Manganese or hardness in excess of 50 gpg. The high salt setting will be needed since these minerals are more difficult to clean out of the resin bed. Note: A resin cleaner will also need to be periodically added to the brine tank to insure proper operation.

See page 25: Res-Up® Feeder Installation Instructions

Working Temperature: This unit must be operated at temperatures between 40°F and 110°F (4°C - 43°C).

Working Pressure: This water softener must be operated on pressures between 30 psi to 125 psi. If the water pressure is higher than 125 PSI, use a pressure reducing valve in the water supply line to the softener.

Voltage = 120V / 60 Hz
Pipe Size = 3/4" and 1"

- At the stated service flow rates, the pressure drop through these devices will not exceed 15 psig.
- The manufacturer reserves the right to make product improvements which may deviate from the specifications and descriptions stated herein, without obligation to change previously manufactured products or to note the change.

Peak flow rates intended for intermittent use only (10 minutes or less) and are for residential applications only. Do not use peak flow rate for commercial applications or for a continuous rate when treated water supplies are geothermal heat pump, swimming pool, etc.

For satisfactory operation, the pumping rate of the well system must equal or exceed indicated backwash flow rate.

All units come with plastic bypass

****Maximum Iron** = 2.0 ppm ferrous (clear water iron)
Maximum Hydrogen Sulfide = 0.0 ppm
Maximum Manganese = .75 ppm
pH = 6.5 to 8.5 with no iron present with iron present 6.5 - 7.5

****NOTE**
SET HARDNESS
This value is the maximum compensated water hardness in grains per gallon of the raw water supply. It is used to calculate the system capacity. If Ferrous Iron is present add 4 gpg for every 1 ppm of Ferrous Iron, 8 gpg for Ferrous Manganese.

CAUTION!

Do not use where the water is microbiologically unsafe or with water of unknown quality without adequate disinfection before or after the unit.



SYSTEM DIMENSIONS

Models	A (Inches)	B (Inches)
75	53"	9"
100	57"	9"
150	63"	10"
200	61"	12"
300	63"	13"

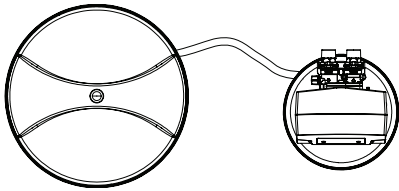

Twin Tank Model

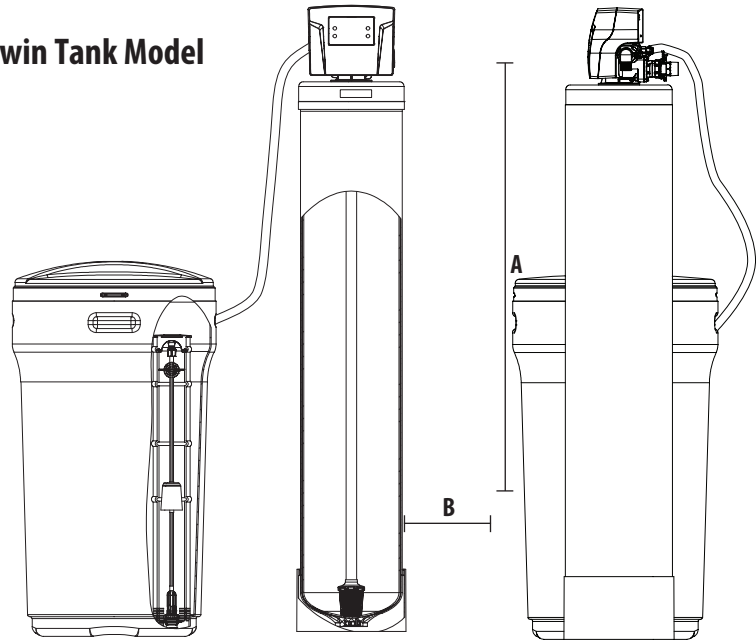

Cabinet Model

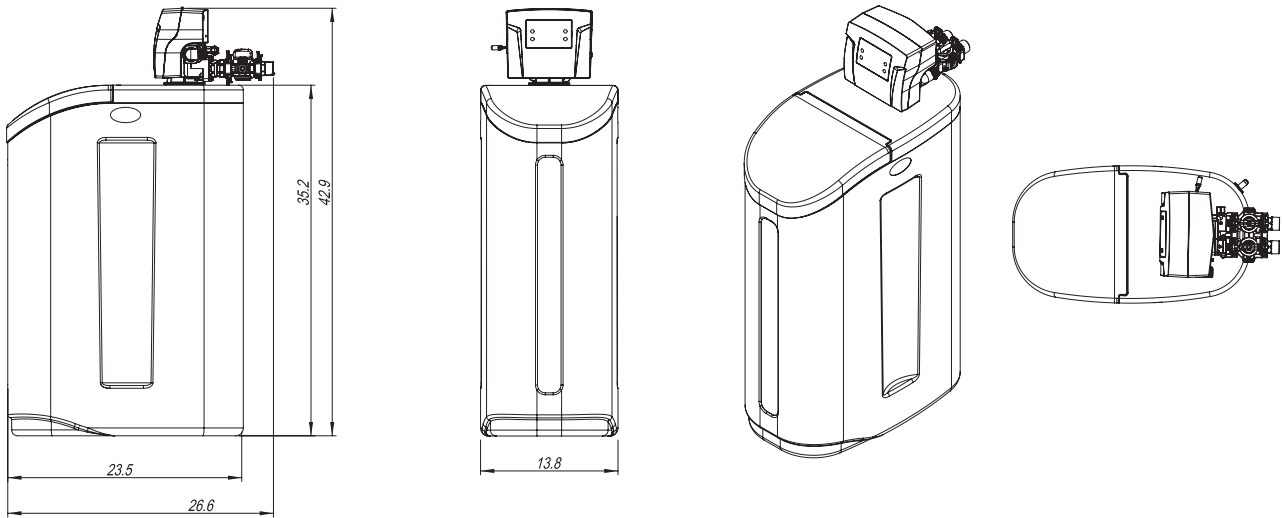

BRINE TANK DIMENSIONS

Model	Color	Liquid Volume		Tank Dimensions (inches)	5 Pack Carton Dimensions (inches)	Salt Capacity		5 Pack Carton Shipping Weight	
		US Gal	Liters	L x W x H	L x W x H	Lbs	Kg	Lbs	Kg
Brine Tanks									
BTR-70	Black	20.3	76.5	15.8 x 32.1	16.7 x 16.7 x 61.0	185.0	92.8	41.6	18.9
BTR-70	Blue	20.3	76.7	15.8 x 32.1	16.7 x 16.7 x 61.0	185.0	92.8	41.6	18.9
BTR-100	Vanilla	29.5	111.5	18.1 x 34.7	18.9 x 18.9 x 65.6	270.0	122.2	52.8	23.9
BTR-100	Black	29.5	111.5	18.1 x 34.7	18.9 x 18.9 x 65.6	270.0	122.2	52.8	23.9
BTR-100	Blue	29.5	111.5	18.1 x 34.7	18.9 x 18.9 x 65.6	270.0	122.2	52.8	23.9
BTR-145	Black	42.3	159.7	20.3 x 37.4	21.9 x 21.9 x 72.2	385.0	174.2	65.6	29.8
BTR-200	Grey	53.0	200.3	23.0 x 40.5	24.6 x 24.6 x 84	700.0	316.7	125.0	56.6
BTS-70	Black	19.0	71.8	13.1 x 13.1 x 34.7	14.4 x 14.4 x 62	175.0	92.8	48.8	22.1
BTS-70	Blue	19.0	71.8	13.1 x 13.1 x 34.7	14.4 x 14.4 x 62	175.0	92.8	48.8	22.1
BTS-100	Vanilla	25.0	94.5	15.0 x 15.0 x 34.7	16.6 x 16.7 x 61	230.0	104.1	54.4	24.7
BTS-100	Black	25.0	94.5	15.0 x 15.0 x 34.7	16.6 x 16.7 x 61	230.0	104.1	54.4	24.7
BTS-100	Blue	25.0	94.5	15.0 x 15.0 x 34.7	16.6 x 16.7 x 61	230.0	104.1	54.4	24.7

* All brine tanks come with salt grid, safety float and brine well

Dimensions BTS70

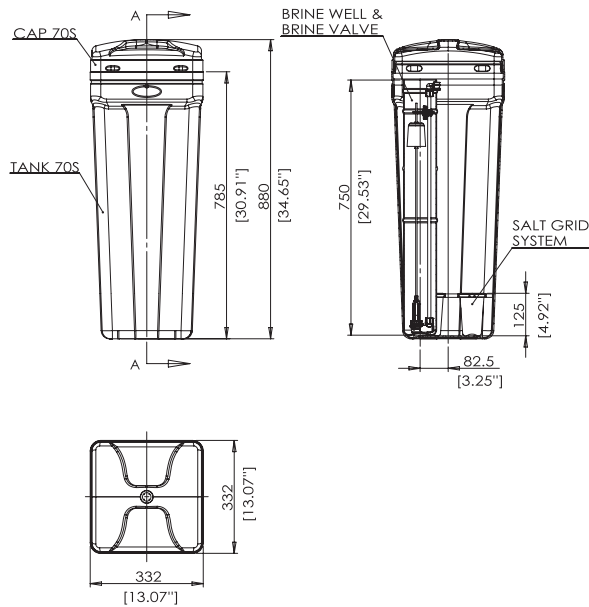

BTS100

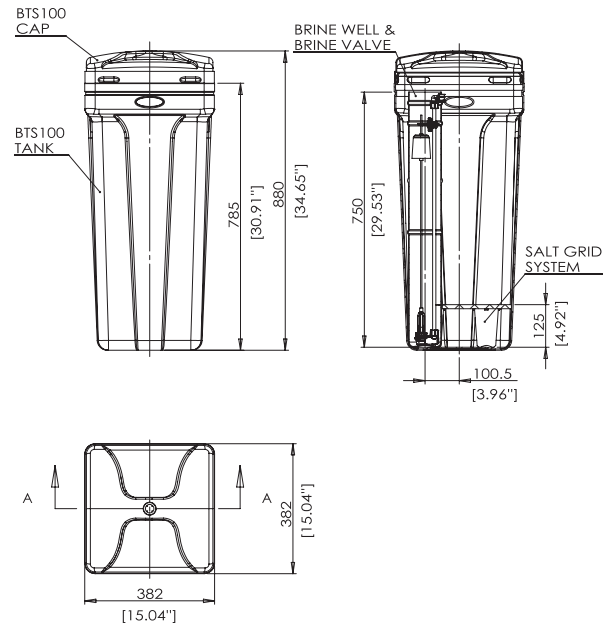

BTR70

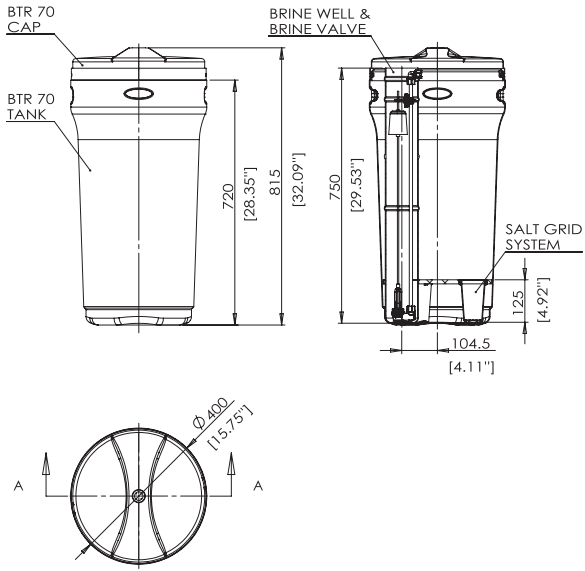

BTR100

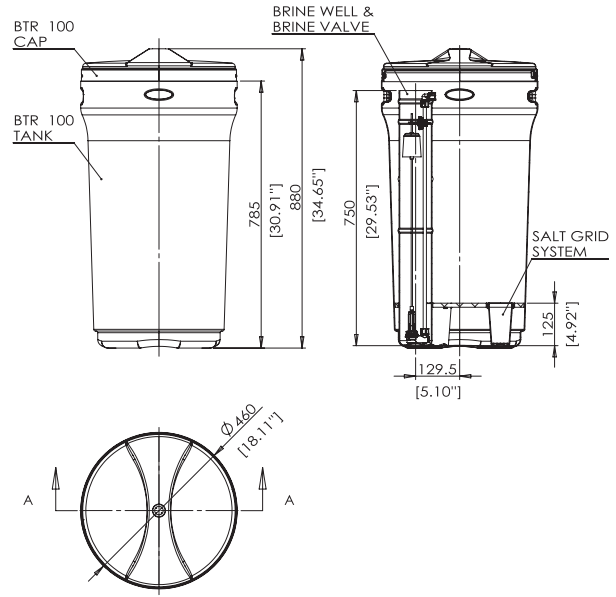

BTR145

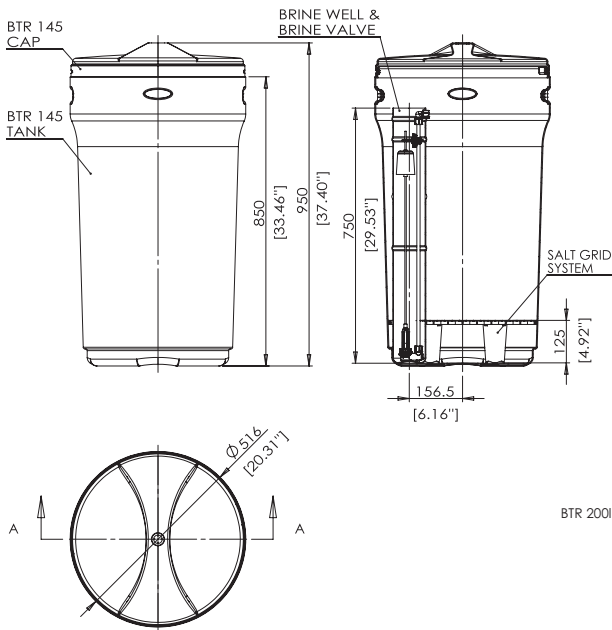

BTR200

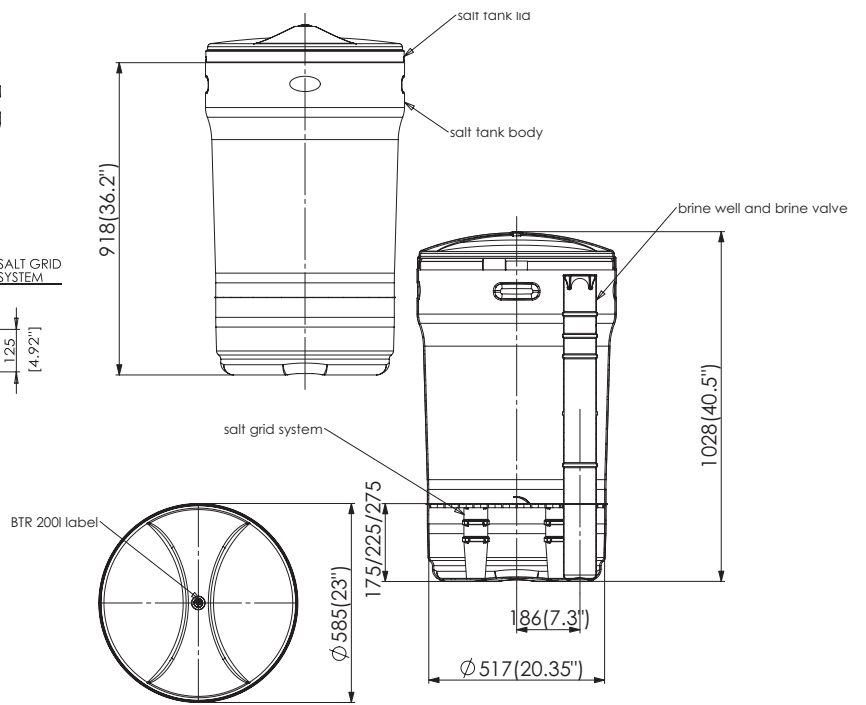

UNPACKING / INSPECTION OF TWIN TANK MODEL

Be sure to check the entire unit for any shipping damage or parts loss. Also note damage to the shipping cartons. Contact the transportation company for all damage and loss claims. The manufacturer is not responsible for damages in transit.

Small parts, needed to install the Softener, are in a parts box. To avoid loss of the small parts, keep them in the parts bag until you are ready to use them.

What is included in the box?

For Models 75, 100, 150, 200, you will expect the following:

1. Control Valve
2. Tank
3. Parts Box
4. Owners Manual
5. Drain Hose & Clamp (Not included in some brands)
6. Brine Tank Assembly

1. Control Valve

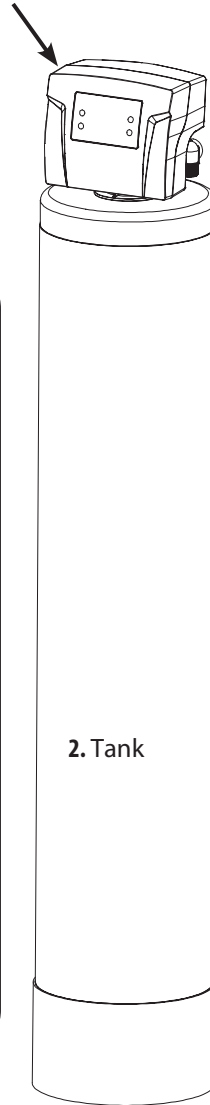

There are 7 Red clips. Please check to make sure you have all of them.

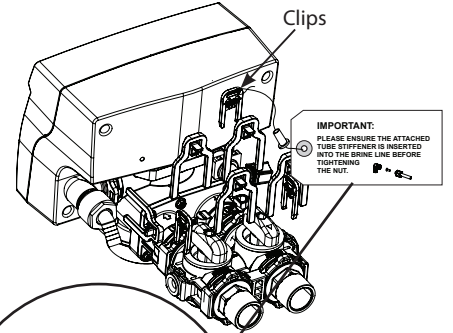

IMPORTANT:
PLEASE ENSURE THE ATTACHED TUBE STIFFENER IS INSERTED INTO THE BRINE LINE BEFORE TIGHTENING THE NUT.

2. Tank

Distributor Tube Inside the Tank

Media Inside the Tank. Media Type will depend on what models were purchased

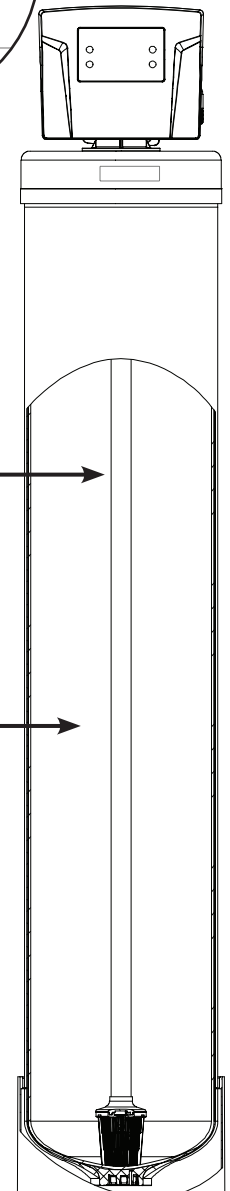

IMPORTANT:
PLEASE ENSURE THE ATTACHED TUBE STIFFENER IS INSERTED INTO THE BRINE LINE BEFORE TIGHTENING THE NUT.

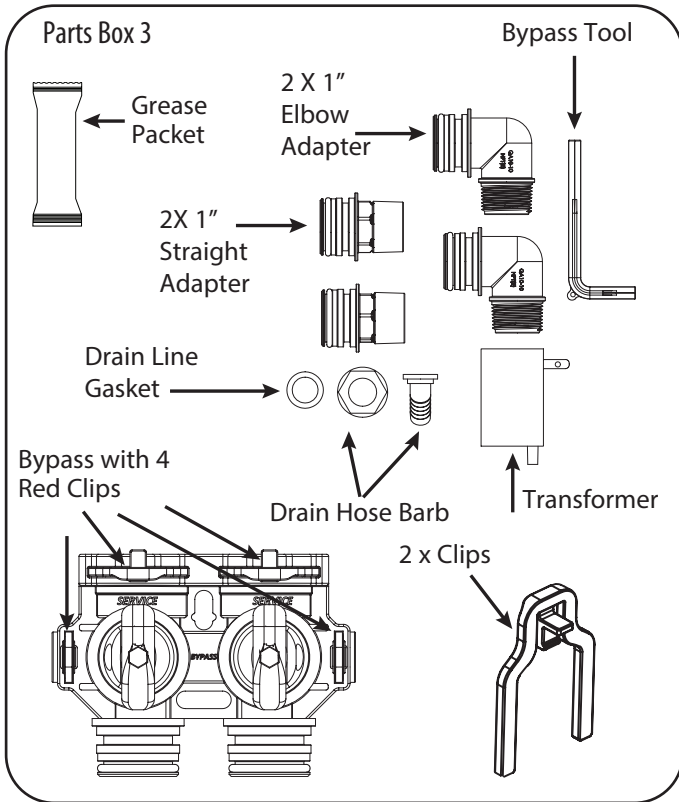

6. Brine Tank Assembly (Round Brine Tank Shown)

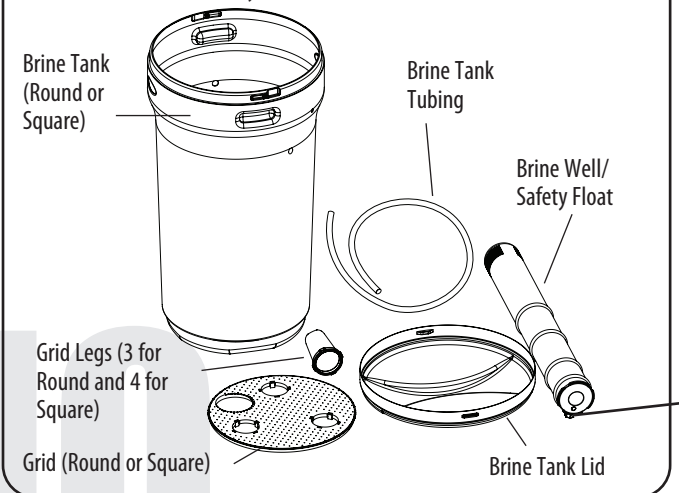

For Models 250 and 300 the media and Control Valve is packaged separately in carton and bags

What is included with 250 and 300 models?

1. Tank (Models 250 and 300 will get an Adapter and Oring attached to the tank)
2. Control Valve with Parts Box
3. Media Boxes (Qty 3 for 250 and Qty 4 for 300)
4. Drain Line and Hose Clamp (Not Included with some models)
5. Brine Tank Assembly

Models 250, 300 will get Adaptor and Oring Shown

There are 7 Red clips. Please check to make sure you have all of them.

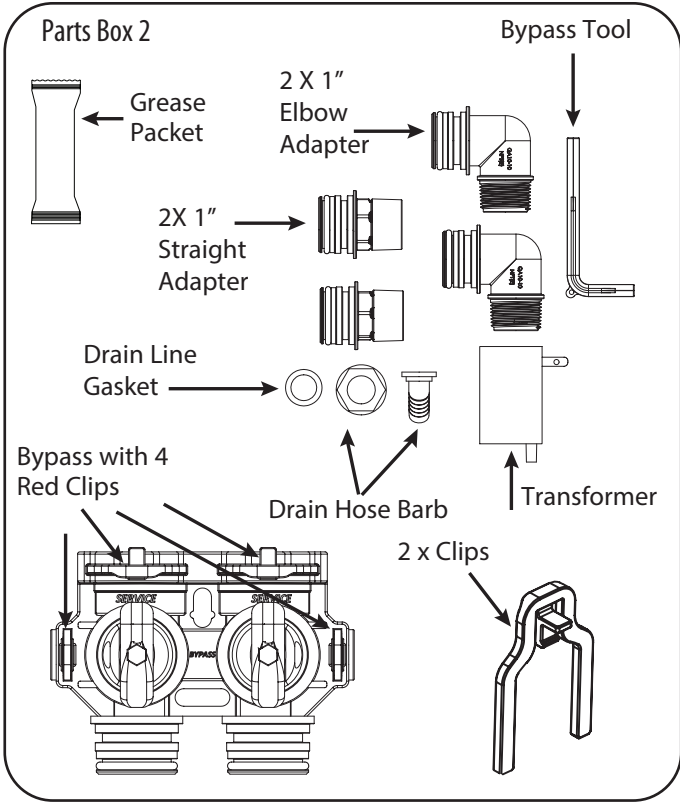

2. Control Valve

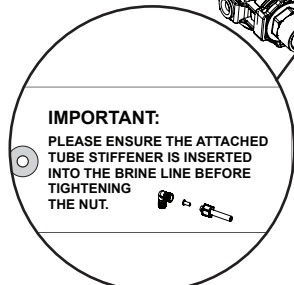
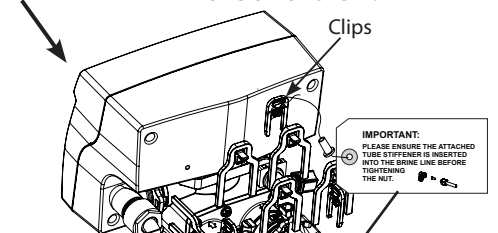

1. Tank

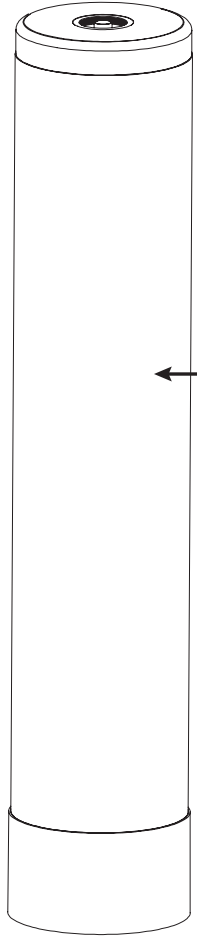

Distributor Tube Inside the Tank

Media Inside the Tank. Media Type will depend on what models were purchased

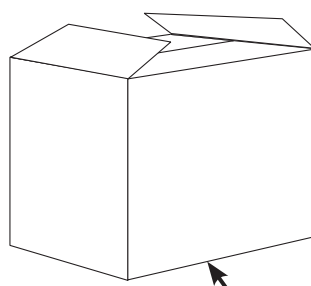
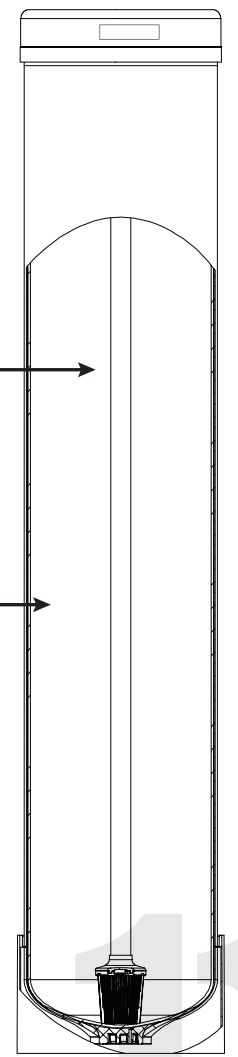

3. Media Box (Qty depends on Models)

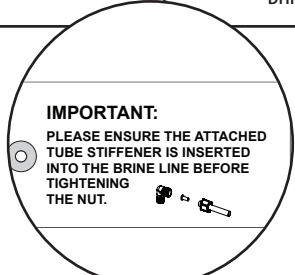
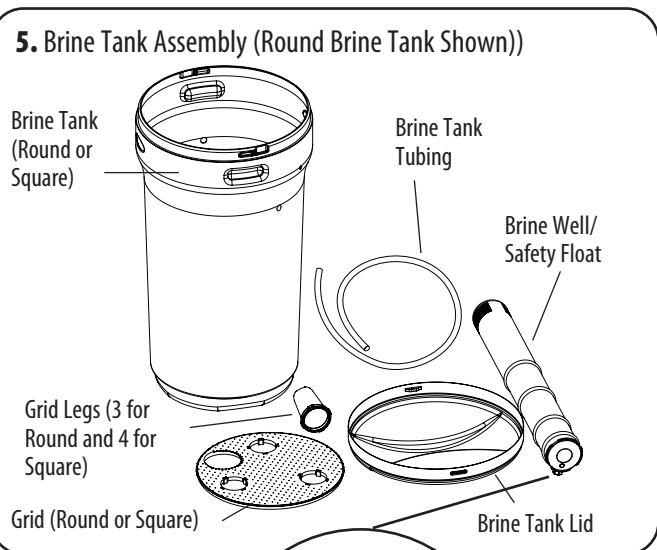

UNPACKING / INSPECTION OF CABINET MODEL

1. Cabinet with Valve attached
2. Parts Box
3. Drain Line and Hose Clamp (Not Included with some models)

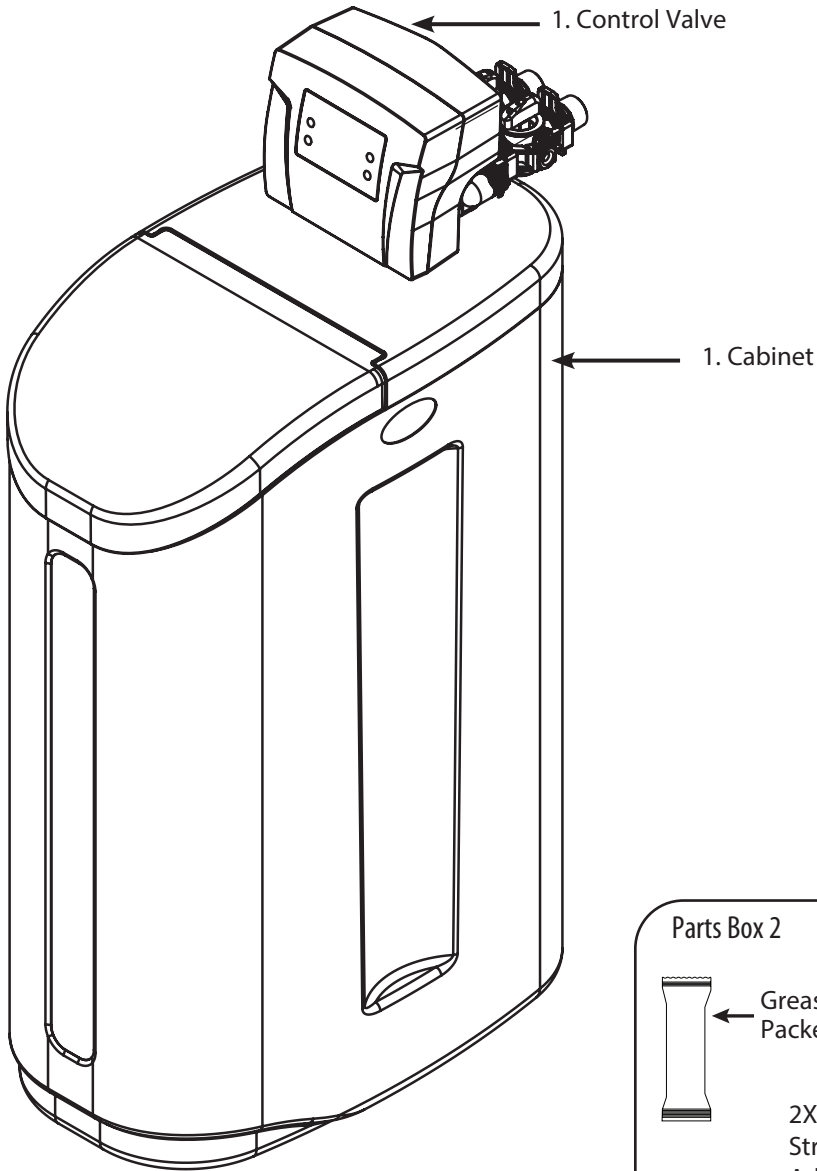

NOTE

Due to transportation and climatic conditions all connections including the valve to the tank need to be checked at time of installation and tightened if necessary.

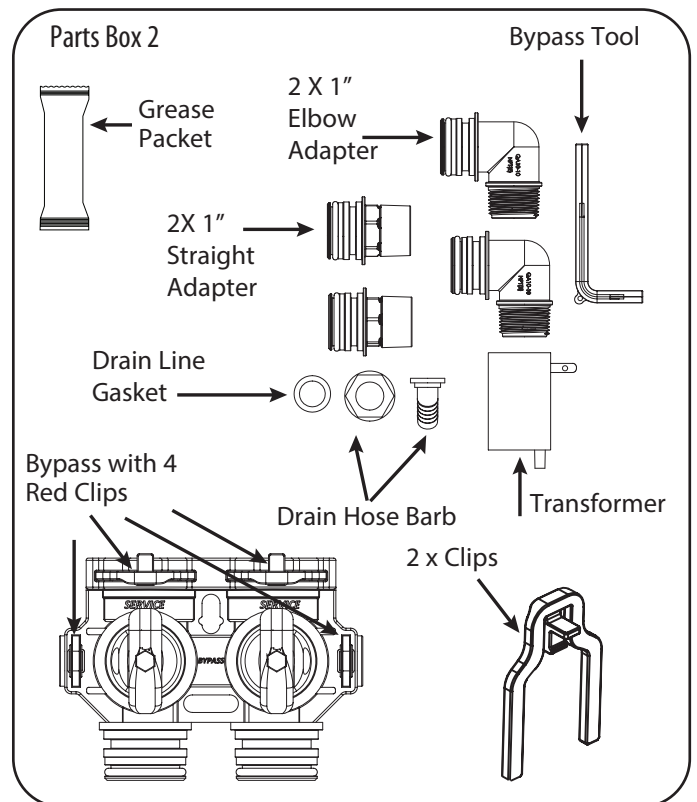

CHECK VALVE TYPE AND VALVE SERIAL

Check to make sure the valve type is what you ordered. The serial # label on the left will show 890 (DF) for downflow valve and 890 (UF) for Upflow valve The right Sticker shows the serial # of the control valve. The middle Sticker is dataplate which provides information of Serial # and Date of Manufacture of complete system. Both Serial # labels are important for troubleshooting.

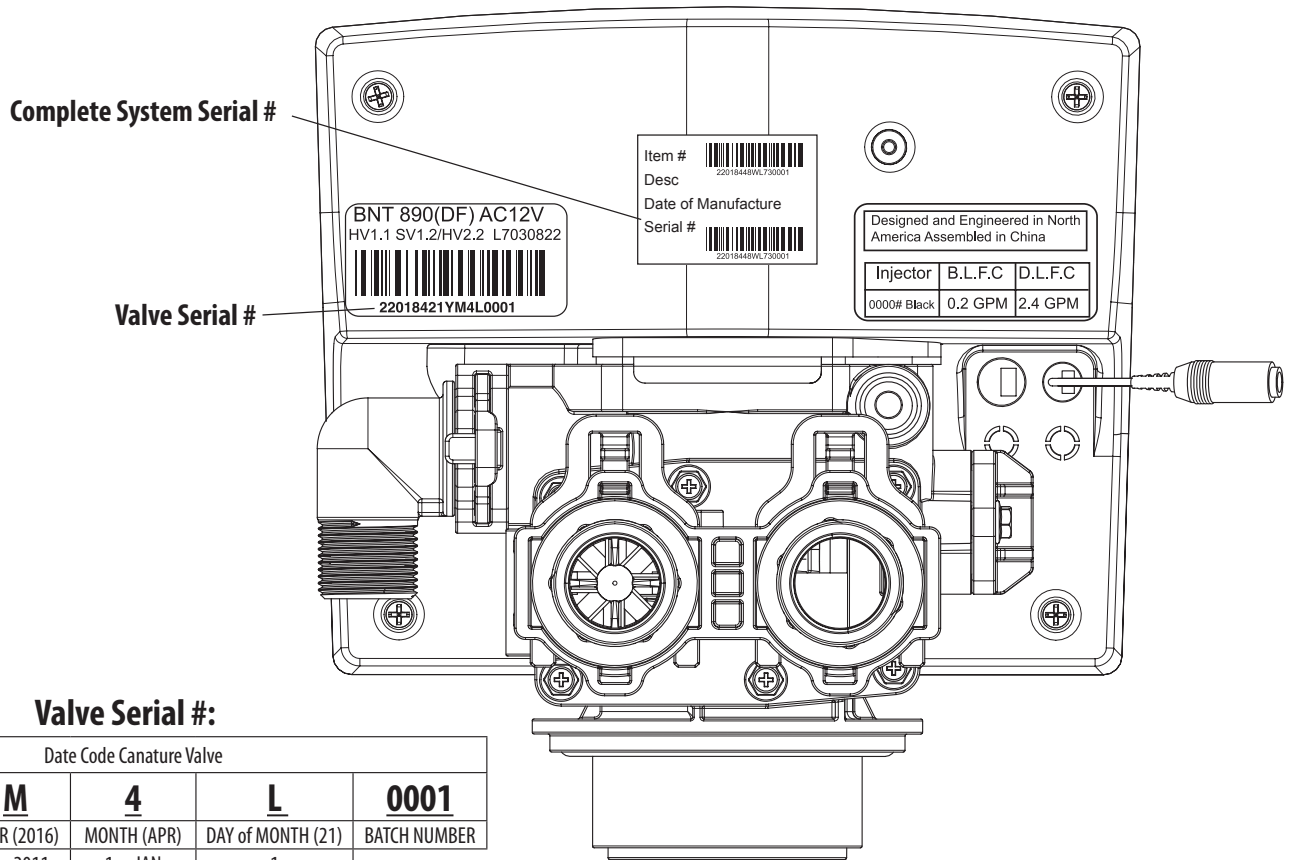

Valve Serial #:

Date Code Canature Valve

22018421Y	M	4	L	0001
PART NUMBER	YEAR (2016)	MONTH (APR)	DAY of MONTH (21)	BATCH NUMBER
	H = 2011	1 = JAN	1	
	I = 2012	2 = FEB	2	
	J = 2013	3 = MAR	3	
	K = 2014	4 = APR	4	
	L = 2015	5 = MAY	5	
	M = 2016	6 = JUN	6	
	N = 2017	7 = JUL	7	
	O = 2018	8 = AUG	8	
	P = 2019	9 = SEP	9	
	Q = 2020	A = OCT	A = 10	
		B = NOV	B = 11	
		C = DEC	C = 12	
			D = 13	
			E = 14	
			F = 15	
			G = 16	
			H = 17	
			I = 18	
			J = 19	
			K = 20	
			L = 21	
			M = 22	
			N = 23	
			O = 24	
			P = 25	
			Q = 26	
			R = 27	
			S = 28	
			T = 29	
			U = 30	
			V = 31	

BEFORE INSTALLATION

Make sure you have a copy of your most recent water test results. If your water has not been tested previously you can contact your supplier of this product to obtain a water sample bottle to be sent to one of our facilities for a free analysis. **It is important that this product not be installed until you have this information.**

In all cases where metal pipe was originally used and is later interrupted by poly pipe or the Noryl bypass valve or by physical separation, an approved ground clamp with no less than #6 copper conductor must be used for continuity, to maintain proper metallic pipe bonding.

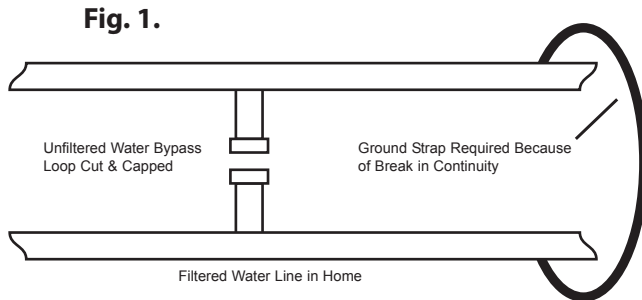

Inspecting and Handling Your New System*

Inspect the equipment for any shipping damage. If damaged, notify the transportation company and request a damage inspection. Damage to cartons should also be noted.

Handle the conditioner unit with care. Damage can result if it is dropped or set on sharp, uneven projections on the floor.

Do not turn the conditioner unit upside down.

To Insure this Product Functions Properly:

Your feed water line size to the unit must be a minimum of 3/4 inch with an operating pressure of no less than 30 psi and no more than 125 psi.

MECHANICAL:

Do not use petroleum based lubricants such as petroleum jelly, oils or hydrocarbon based lubricants. Use only 100% silicone lubricants (grease packet provided in parts kit). All plastic connections should be hand tightened only. Teflon tape may be used on connections that do not use an O-ring seal. Do not use pliers or pipe wrenches except where indicated by Nut shape (eg. pipe adapters) All plumbing must be completed according to local codes. Soldering connections should be done before connecting any pieces to the pipe as excessive heat can damage them.

Tools Required for Installation:

NOTE: We recommend installation only be completed by a competent installer or plumbing professional to insure this product is installed in accordance with local plumbing codes.

- ▶ Two adjustable wrenches
- ▶ Additional tools may be required if modification to home plumbing is required.
- ▶ Plastic inlet and outlet fittings are included with the conditioner. To maintain full valve flow, 3/4" or 1" pipes to and from the conditioner fittings are recommended. You should maintain the same, or larger, pipe size as the water supply pipe, up to the conditioner inlet and outlet.
- ▶ Use copper, brass, or PEX pipe and fittings.
- ▶ Some codes may also allow PVC plastic pipe.
- ▶ ALWAYS install the included bypass valve, or 3 shut-off valves. Bypass valves let you turn off water to the conditioner for repairs if needed, but still have water in the house pipes.
- ▶ 5/8" OD drain line is needed for the valve drain. A 10' length of hose is not included with some brands.

NOTE

All government codes and regulations governing the installation of these devices must be observed.



CAUTION!

If the ground from the electrical panel or breaker box to the water meter or underground copper pipe is tied to the copper water lines and these lines are cut during installation of the Noryl bypass valve and/or poly pipe, an approved grounding strap must be used between the two lines that have been cut in order to maintain continuity. The length of the grounding strap will depend upon the number of units being installed and/or the amount of copper pipe being replaced with plastic pipe.

See Fig. 1.

NOTE

Check your local electrical code for the correct clamp and cable size.

NOTE

If a severe loss in water pressure is observed when the conditioner unit is initially placed in service, the conditioner tank may have been laid on its side during transit. If this occurs, backwash the conditioner to "reclassify" the media.

*NOTE

Due to transportation and climatic conditions all connections including the valve to the tank need to be checked at time of installation and tightened if necessary.

PREPARATIONS



The unit should be depressurized before installing or replacing media

1. Media Installation (When Necessary). Models including and higher than 2 CF (Models 250,300) of media are shipped with separate media in pails or boxes. Models lower than 2 CF of media come loaded with media and this step can be skipped for new installation.

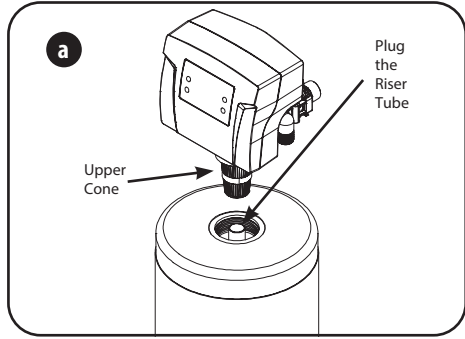

a) Lube the bottom oring (picture **d**) and attach the upper cone to the valve.

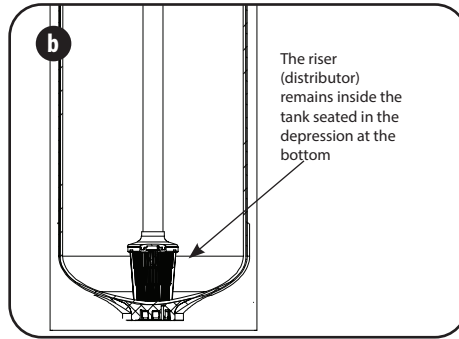

b) Temporarily plug the open end of the riser tube to ensure that no resin or gravel falls down into the distribution. The riser (distributor) remains inside the tank seated in the depression at the bottom. Plug tube with a tape. Remove after media is loaded.

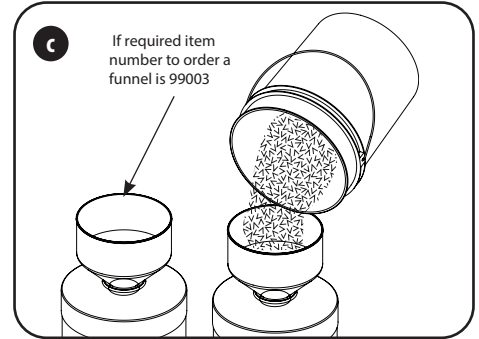

c) Fill support bed first. The media will not always spill down inside the tank and may need to be swept inside. The large funnel (sold separately makes filling the tank easier and neater. (Or an empty 1 gallon or 4 liter container with the bottom cut out makes a good funnel.)

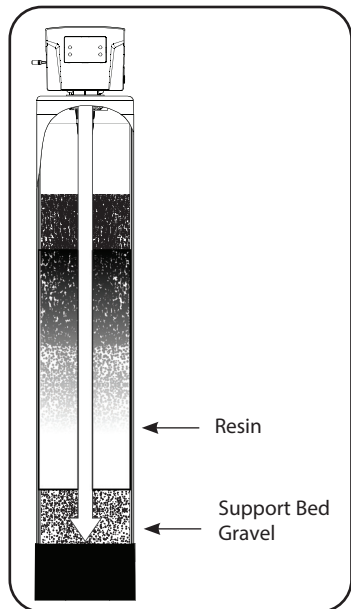

Fill tank one quarter full of water to protect distribution during gravel installation. Place the media into the tank in the order indicated above. Slowly and carefully add the gravel support bed and the filtration media leveling each layer as it is placed into the tank.

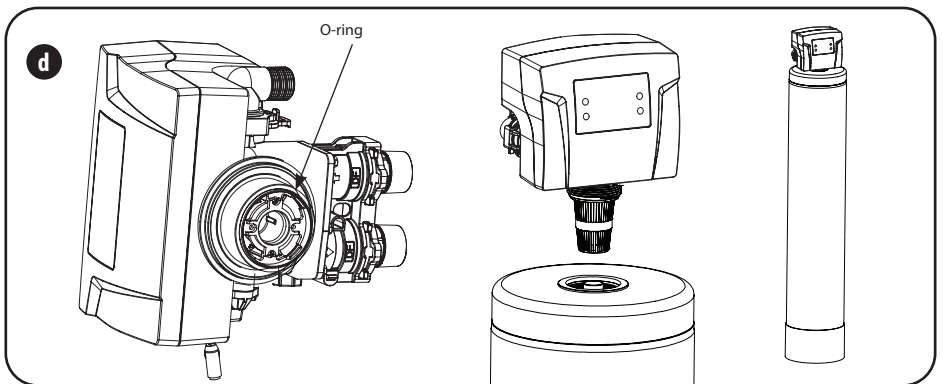

d) Unplug the riser tube, carefully position the valve over it and turn the valve into the threads in the fiberglass tank, tightening securely into tank. Note: Ensure that the internal O-ring in the valve fits securely over the riser tube. Silicone grease (part # 92360) or other food grade lubricant may be applied to the O-ring to ease installation of the riser tube.

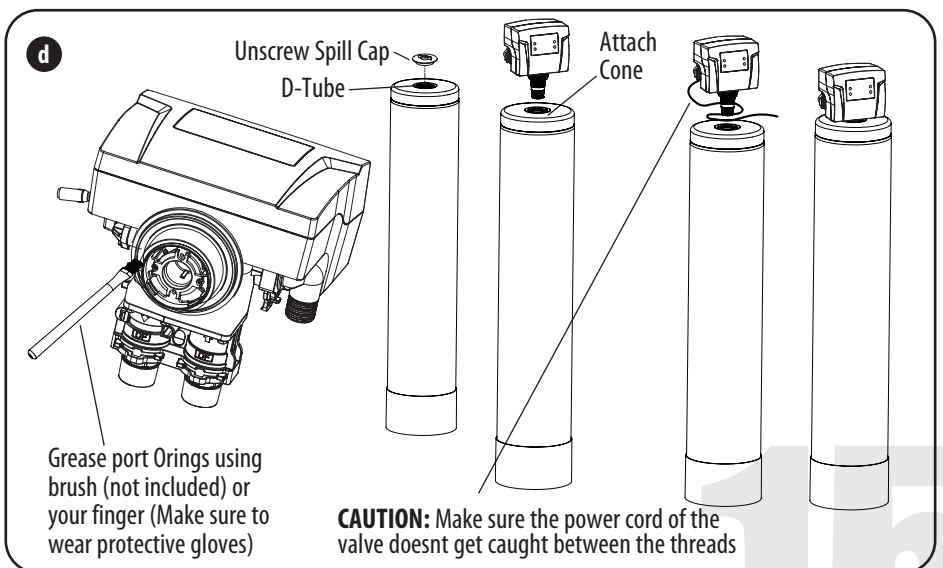

d) Lube the bottom Valve Orings with the grease supplied, Attach the Upper Cone. Unscrew the spill cap. Carefully Slide the D-Tube inside the Valve and Screw the Valve inside the Tank such that the power cord doesnt get caught between the valve and the tank.

CAUTION!
Make sure that the unit is de-pressurized before conducting this task.

CAUTION!
DO NOT use petroleum based lubricants as they will cause swelling of O-ring seals.



PREPARATIONS

Planning Your Installation

Select the location of your conditioner tank with care. Various conditions which contribute to proper location are as follows:

1. All installation procedures must conform to local and state or provincial plumbing codes.
2. Outside faucets used to water lawns and gardens should not supply untreated water, replace untreated water with feed water to the unit. If necessary to do this please install check valve, **see page 18**. A new water line is often required to be connected to supply untreated water to the inlet of the water conditioner and to the outside faucets.
3. Locate as close as possible to the water supply source.
4. Locate as close as possible to a floor or laundry tub drain.
5. Locate in correct relationship to other water conditioning equipment. if closer than 10 feet please install check valve in accordance with local plumbing codes.
6. Conditioners should be located in the supply line before the water heater. Temperatures above 110°F (43°C) will cause damage to conditioners.
7. Do not install a conditioner or conditioner in a location where freezing temperatures occur. Freezing may cause permanent damage to this type of equipment and will void the factory warranty.
8. Allow sufficient space around the unit for easy servicing.
9. Keep the conditioner out of direct sunlight. The sun's heat may soften and distort plastic parts.

INSTALLATION STEPS

1. Determine the best location for your water conditioner, bearing in mind the location of your water supply lines, drain line and 120 volt AC electrical outlet. Subjecting the conditioner to freezing or temperatures above 43°C (110°F) will void the warranty.

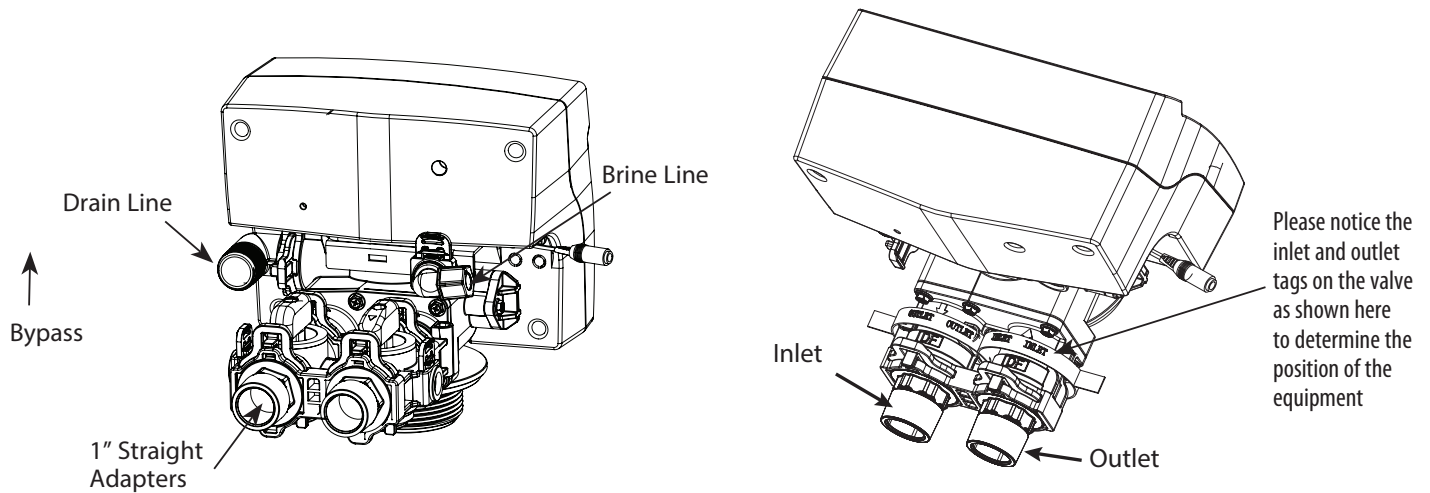

2. Make sure the bypass is attached well to the control valve. Connect the straight or elbow connectors to the bypass with red clips. Connect the inlet and outlet of the water conditioner to the plumbing of the house. The control valve must not be submitted to temperatures above 43°C (110°F). When sweat fittings are used, to avoid damaging the control valve, solder the threaded copper adapters to the copper pipe and then, using Teflon tape, screw the assembly into the bypass valve.
Do not use pipe thread compound as it may attack the material in the valve body.
3. Apply Teflon Tape and Orings to the fittings
4. Connect Conditioner to the house plumbing. Any solder joints near the valve must be done before connecting any piping to the valve. Always leave at least 6" (152 mm) between the valve and joints when soldering pipes that are connected to the valve. Failure to do this could cause damage to the valve.
5. **Drain Line connection:** Attach 1/2" ID, 5/8" OD drain hose to the hose barb and tighten securely with a hose clamp. Run the drain line to a floor drain or a laundry drain. Complete any necessary plumbing.

INSTALLATION STEPS

6. ***Using the Allen Key (included), place the unit in the bypass position.** Slowly turn on the main water supply. At the nearest cold treated water tap nearby remove the faucet screen, open the faucet and let water run a few minutes or until the system is free of any air or foreign material resulting from the plumbing work.

*Automatic Water Bypass

The regeneration cycle lasts approximately 1.5 hours to 3.0 hours depending on the specific model, after which treated water service will be restored. During regeneration, untreated water is automatically bypassed for use in the household. Hot water should be used as little as possible during this time to prevent hard water from filling the water heater.

IMPORTANT: This is why the automatic regeneration is set for sometime during the night and manual regenerations should be performed when little or no water will be used in the household. See 'STARTUP & PROGRAMMING', pages 16 & 19 for more info on Regeneration Programming.

*Manual Water Bypass

In case of an emergency such as conditioner maintenance, you can isolate your water conditioner from the water supply using the bypass valve located at the back of the control. In normal operation the bypass is open with the ON/OFF knobs in line with the INLET and OUTLET pipes. To isolate the conditioner, simply rotate the knobs clockwise (as indicated by the word BYPASS and arrow) until they lock. You can use your water related fixtures and appliances as the water supply is bypassing the conditioner. However, the water you use will be hard. To resume treated service, open the bypass valve by rotating the knobs counterclockwise. **Please make sure bypass knobs are completely open otherwise the unconditioned water could bypass through the valve.**

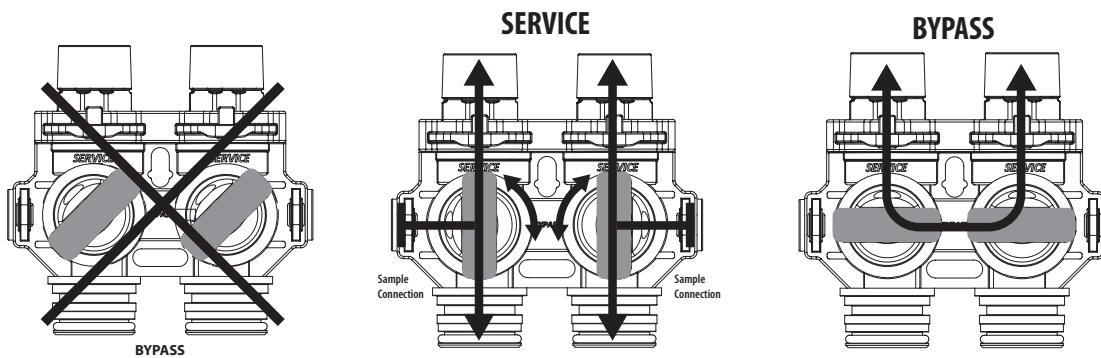

7. Make sure there are no leaks in the plumbing system before proceeding. Close the water tap when water runs clean.
8. Open the brine tank salt lid and add water until there is approximately 3" (75 mm) of water in the tank. Do not add salt to the brine tank at this time.

NOTE

If the plumbing system is used as the ground leg of the electric supply, continuity should be maintained by installing ground straps around any nonconductive plastic piping used in installation.
- See page 14

NOTE

Before starting installation, read page 24, **Plumbing System Clean-Up**, for instructions on some procedures that may need to be performed first.

INSTALLING BRINE TANK*

a) Attach the three brine grid legs to grid plate. The legs will snap on to the tabs of the salt plate making a "click" sound. For square brine tank there are four legs.)

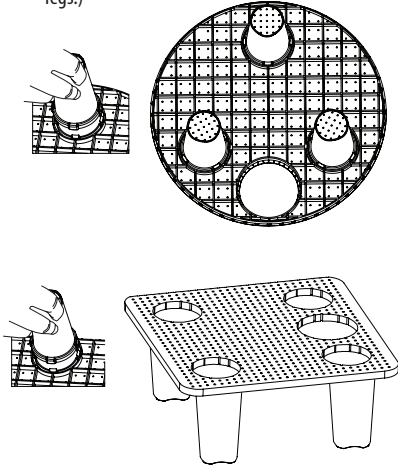

b) Insert the brine well assembly inside the grid plate as well below.

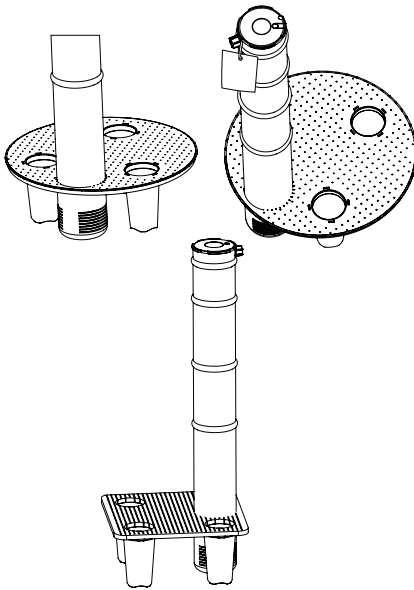

c) Drop the brine grid with brine well inside the brine tank such that the nut fitting faces the hole on the brine tank. Then press the grid evenly inside the brine tank until the brine grid legs touches the bottom of the brine tank.

IMPORTANT:
IN ROUND BRINE TANK, IT IS IMPORTANT TO ALIGN THE HANDLE TO THE BRINE WELL AS SHOWN

The hole in the brine tank should line up with the brine line as shown for round and square brine tank.

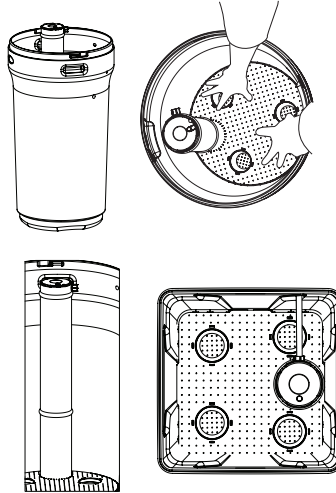

Attaching Brine Tubing to the Brine Line of the Valve

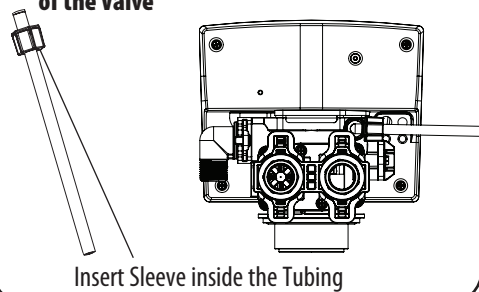

Insert Sleeve inside the Tubing

d) Take the brine tube and insert the nut and plastic sleeve as shown below.

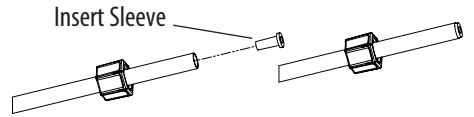

e) Insert the tube in the float assembly elbow and hand tighten the nut. In many cases the brine line already come installed from the factory. Leave the other end of the brine line tube inside the brine tank

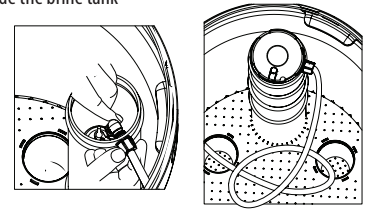

f) For installation of brine tank at the installation site, pull the other end of the brine tube from the hole on the brine tank. The completed assembly is shown below.

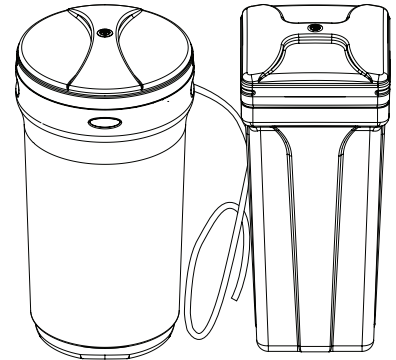

*NOTE

Resin Cleaner

An approved resin cleaner **MUST** be used on a regular basis if your water supply contains iron.

See page 25 - Res-Up® Feeder Installation Instructions

WATER SOFTENER INSTALLATION

Connect Softener to the House Plumbing Any solder joints near the valve must be done before connecting any piping to the valve. Always leave at least 6" (152 mm) between the valve and joints when soldering pipes that are connected to the valve. Failure to do this could cause damage to the valve.

Upflow Water Softener Installation

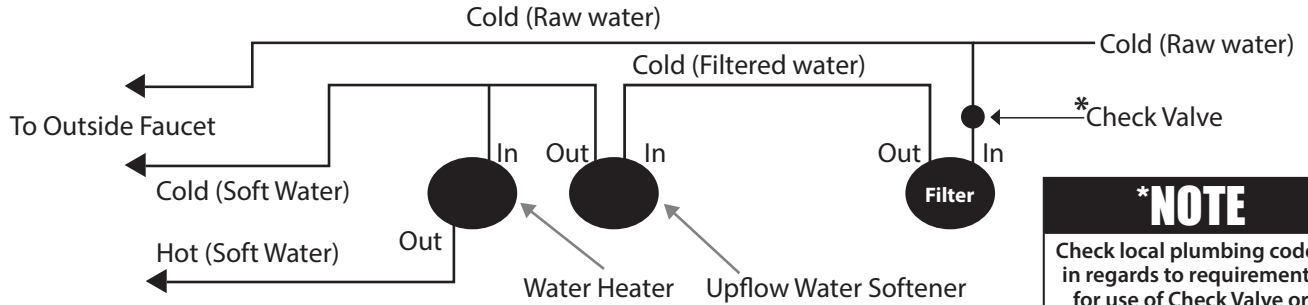

***NOTE**
Check local plumbing codes in regards to requirements for use of Check Valve or back flow prevention or vacuum breaker

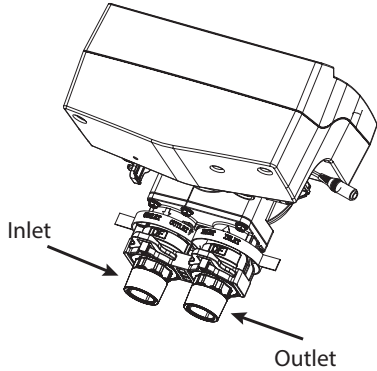
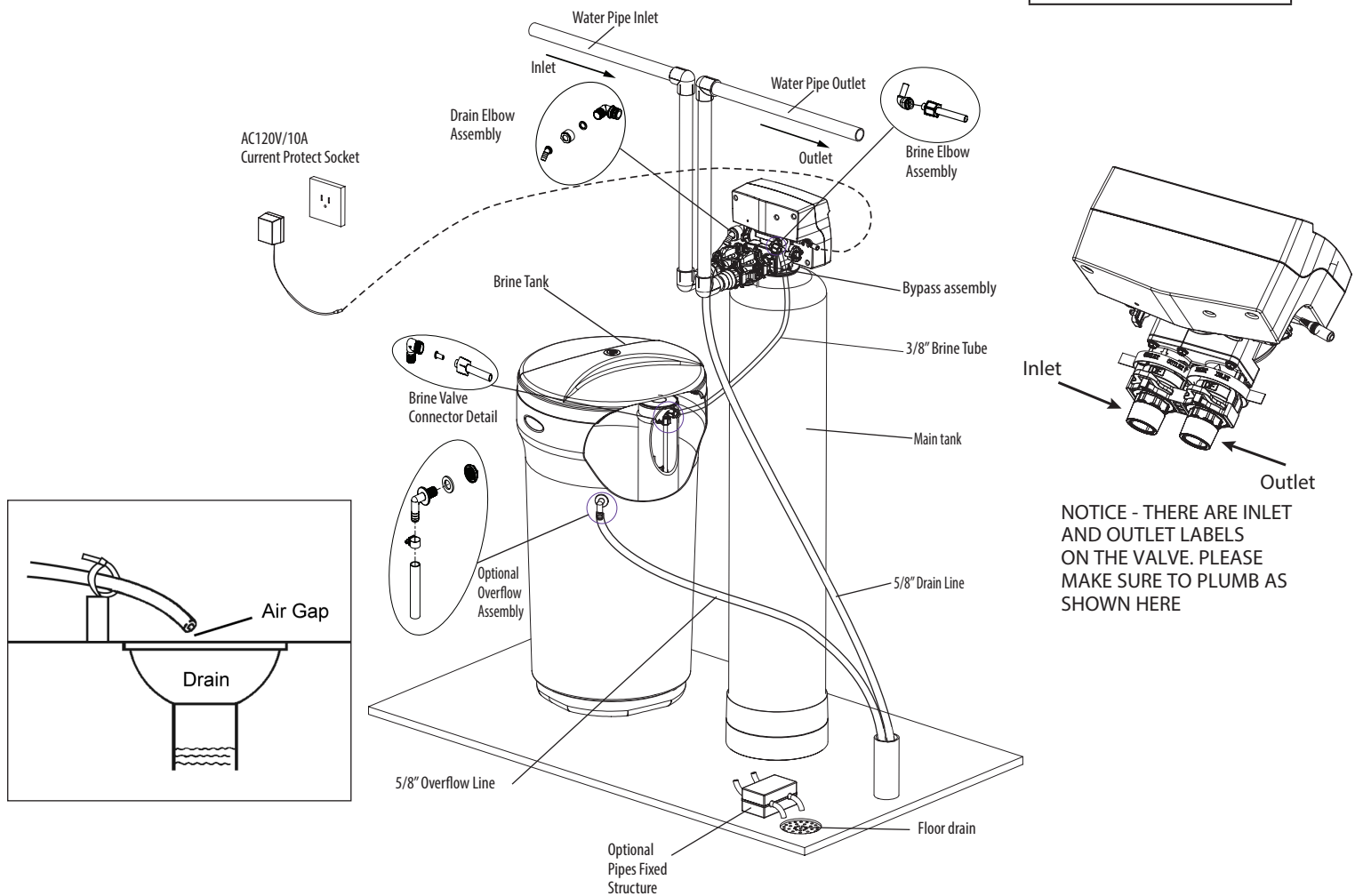

NOTICE - THERE ARE INLET AND OUTLET LABELS ON THE VALVE. PLEASE MAKE SURE TO PLUMB AS SHOWN HERE

NOTE
Waste connections or drain outlet shall be designed and constructed to provide for connection to the sanitary waste system through an air-gap of 2 pipe diameters or 1 inch (22 mm) whichever is larger.

CAUTION!
Never insert drain line directly into a drain, sewer line, or trap. Always allow an air gap between the drain line and the wastewater to prevent the possibility of sewage being back-siphoned into the conditioner.

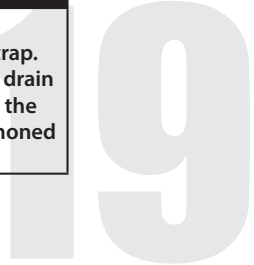

WATER SOFTENER INSTALLATION

Connect Softener to the House Plumbing Any solder joints near the valve must be done before connecting any piping to the valve. Always leave at least 6" (152 mm) between the valve and joints when soldering pipes that are connected to the valve. Failure to do this could cause damage to the valve.

Downflow Water Softener Installation

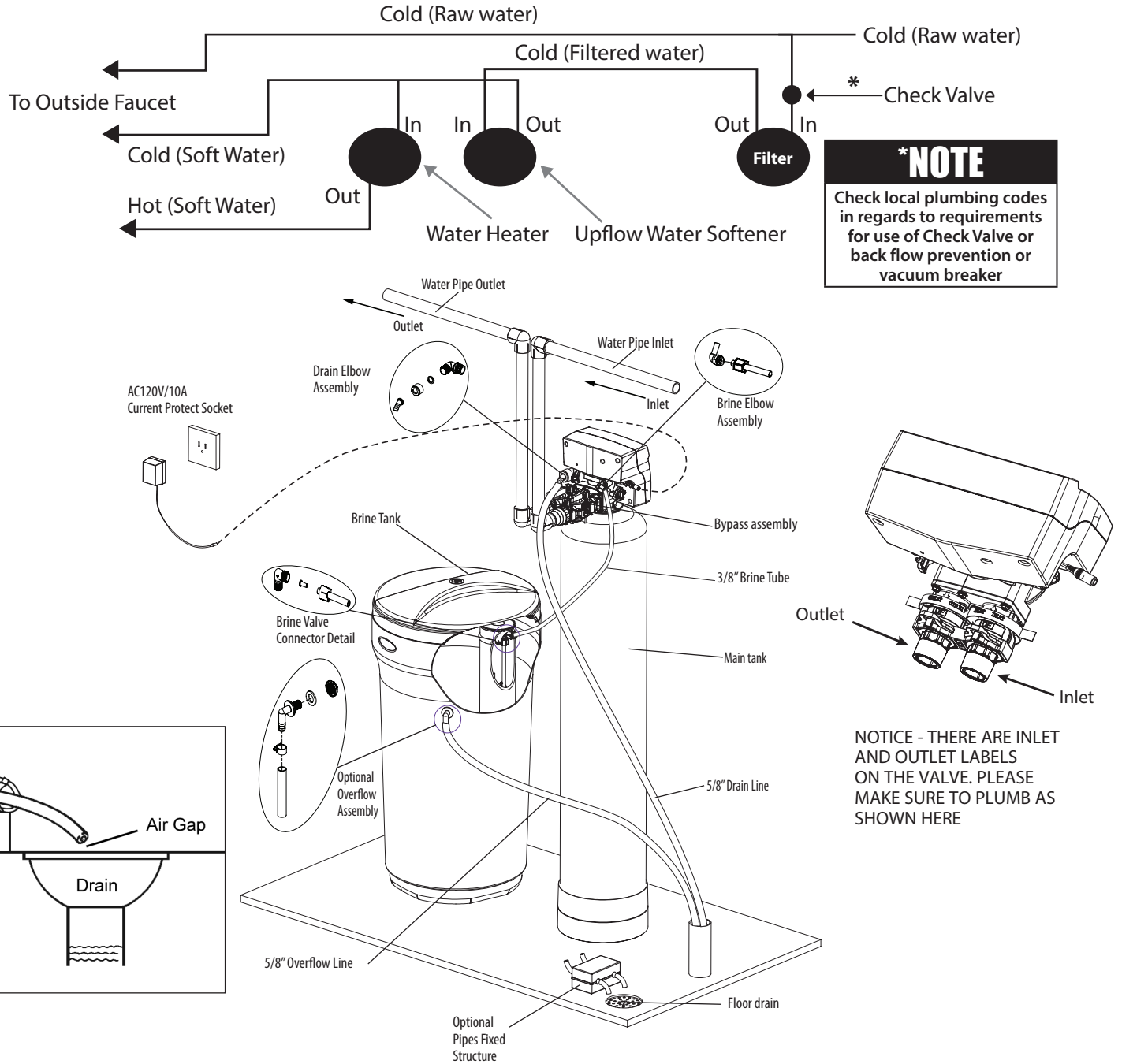

***NOTE**
Check local plumbing codes in regards to requirements for use of Check Valve or back flow prevention or vacuum breaker

NOTICE - THERE ARE INLET AND OUTLET LABELS ON THE VALVE. PLEASE MAKE SURE TO PLUMB AS SHOWN HERE

NOTE
Waste connections or drain outlet shall be designed and constructed to provide for connection to the sanitary waste system through an air-gap of 2 pipe diameters or 1 inch (22 mm) whichever is larger.

CAUTION!
Never insert drain line directly into a drain, sewer line, or trap. Always allow an air gap between the drain line and the wastewater to prevent the possibility of sewage being back-siphoned into the conditioner.

CABINET WATER SOFTENER INSTALLATION

Connect Softener to the House Plumbing Any solder joints near the valve must be done before connecting any piping to the valve. Always leave at least 6" (152 mm) between the valve and joints when soldering pipes that are connected to the valve. Failure to do this could cause damage to the valve.

Upflow Cabinet Water Softener Installation

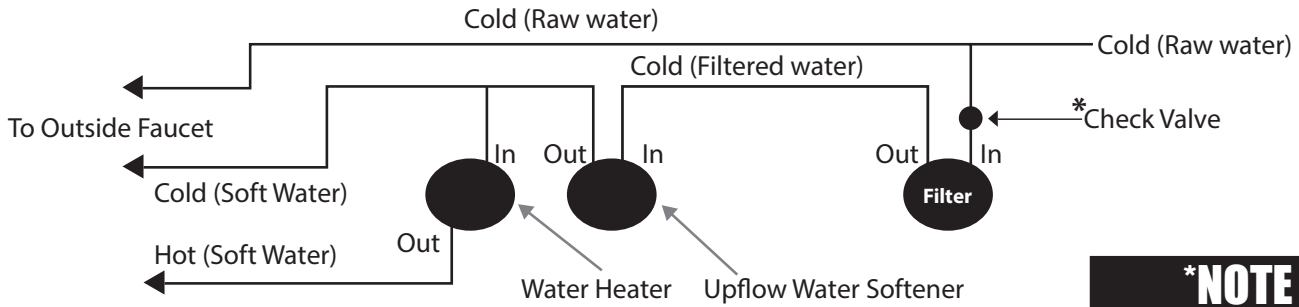

***NOTE**
Check local plumbing codes in regards to requirements for use of Check Valve or back flow prevention or vacuum breaker

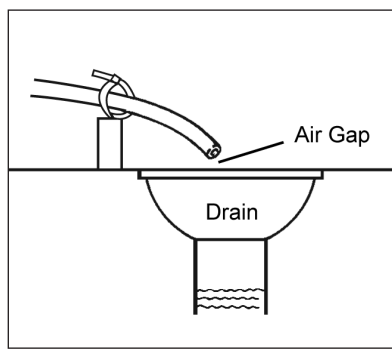
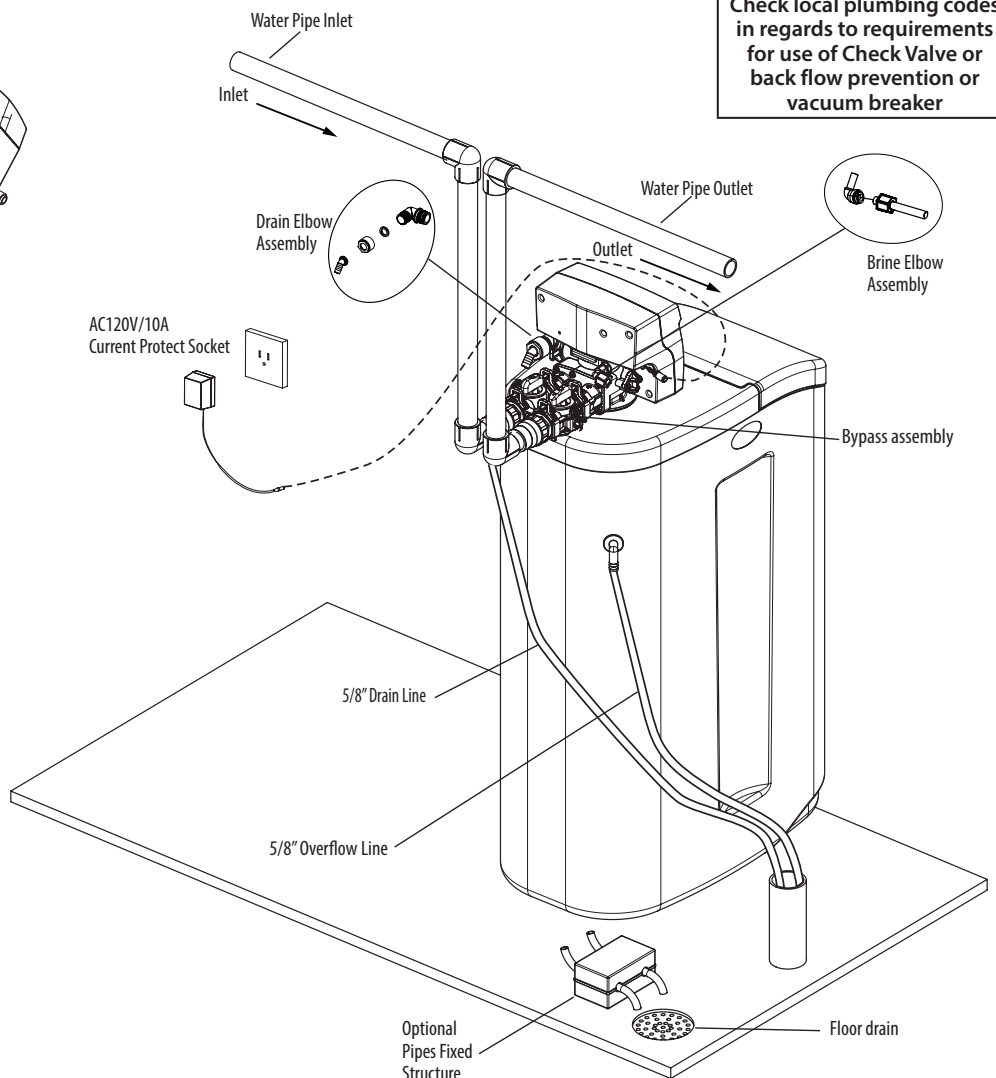
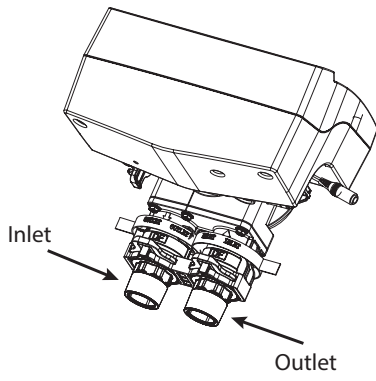

CAUTION!
Never insert drain line directly into a drain, sewer line, or trap. Always allow an air gap between the drain line and the wastewater to prevent the possibility of sewage being back-siphoned into the conditioner.

NOTE
Waste connections or drain outlet shall be designed and constructed to provide for connection to the sanitary waste system through an air-gap of 2 pipe diameters or 1 inch (22 mm) whichever is larger.

CABINET WATER SOFTENER INSTALLATION

Connect Softener to the House Plumbing Any solder joints near the valve must be done before connecting any piping to the valve. Always leave at least 6" (152 mm) between the valve and joints when soldering pipes that are connected to the valve. Failure to do this could cause damage to the valve.

Downflow Cabinet Water Softener Installation

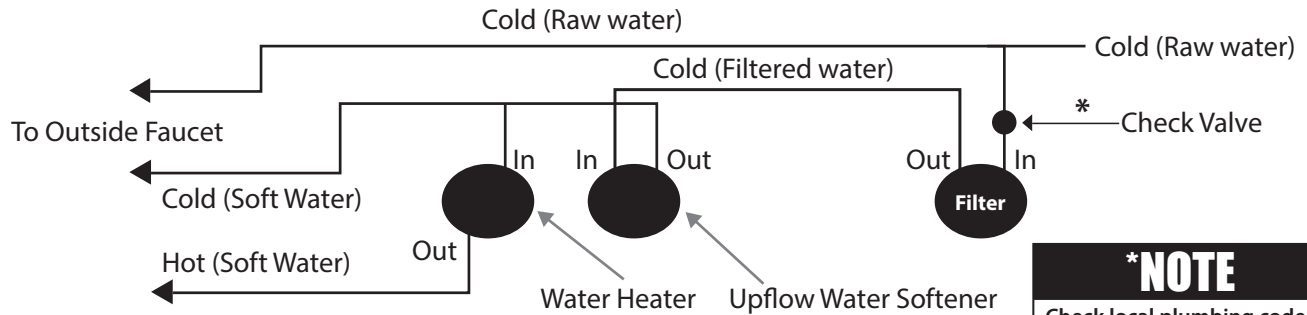

***NOTE**
Check local plumbing codes in regards to requirements for use of Check Valve or back flow prevention or vacuum breaker

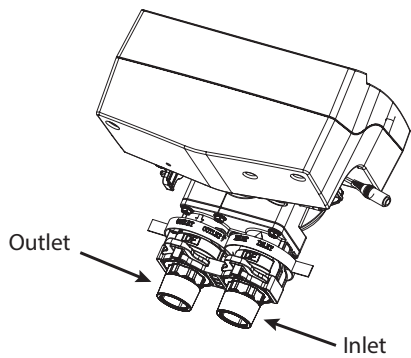

NOTICE - THERE ARE INLET AND OUTLET LABELS ON THE VALVE. PLEASE MAKE SURE TO PLUMB AS SHOWN HERE

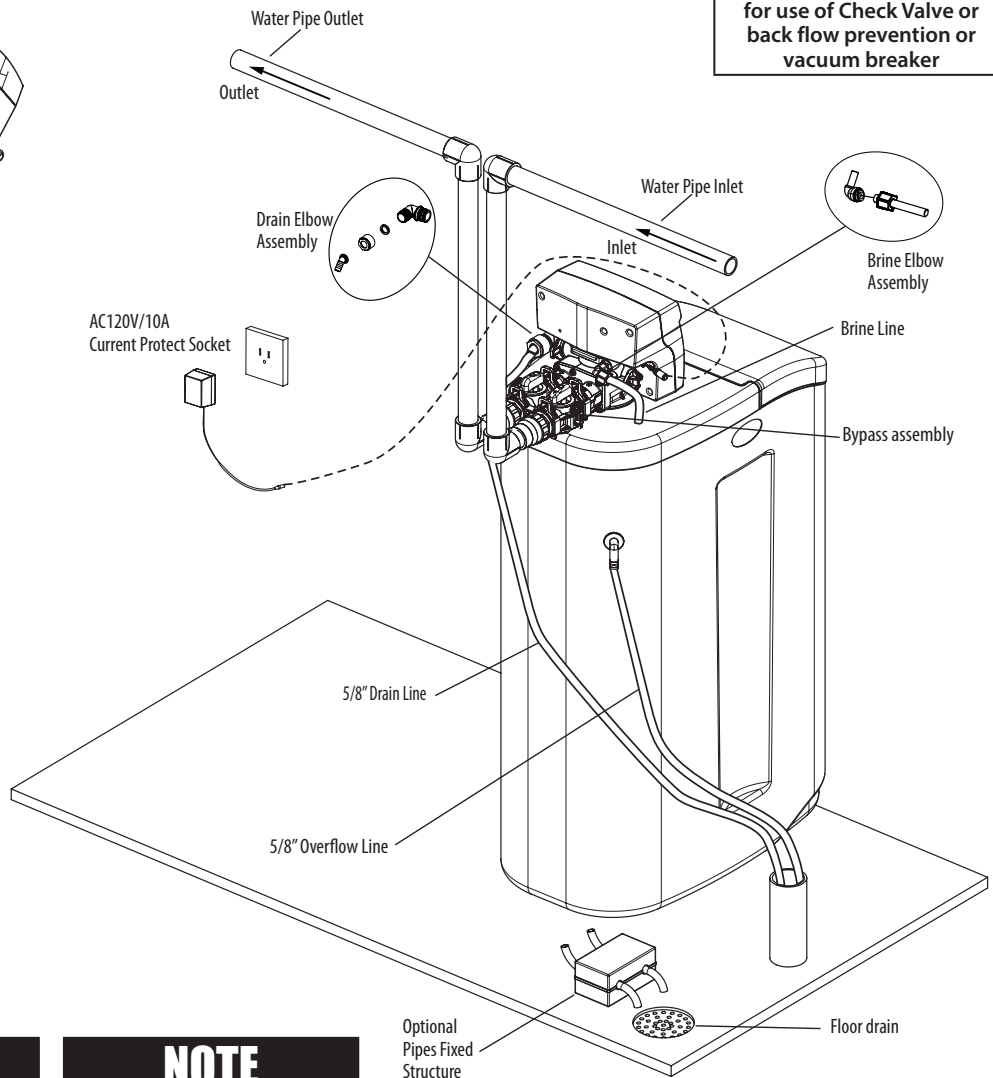
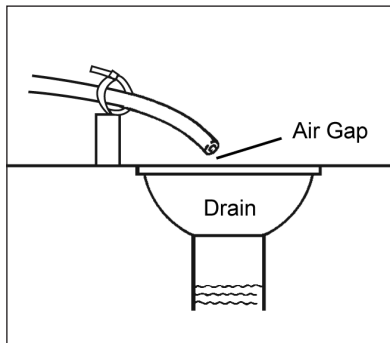

CAUTION!
Never insert drain line directly into a drain, sewer line, or trap. Always allow an air gap between the drain line and the wastewater to prevent the possibility of sewage being back-siphoned into the conditioner.

NOTE
Waste connections or drain outlet shall be designed and constructed to provide for connection to the sanitary waste system through an air-gap of 2 pipe diameters or 1 inch (22 mm) whichever is larger.

STARTUP & PROGRAMMING

STEP 1. Connect the Transformer to the Valve

Plug the 12-volt transformer into a 120 VAC 60 Hz outlet.

The control valve is controlled with simple, user-friendly electronics displayed on an LCD screen. When power is connected, the screen will show the following information in sequence:

1. Date & Time
2. Regeneration Days (Time interval between backwashes)
3. Remaining Days (days left before backwash begins)
4. Regeneration Time (Time of day when backwash starts)
5. Last Regeneration Date (Last date when system backwashed)
6. Current Flow Rate (GPM) (flow rate of water being currently used)
7. Peak Flow Rate (GPM) (Max recorded flow rate of the water)

STEP 2. Add Water to Brine Tank

Open the brine tank /cabinet salt lid and add water as per the info below. Do not add salt to the brine tank at this time.

BRINE TANK MODEL – Water to be Added at the Time of Installation:

BTR-100 (18.1" x 34.7") - 2.5 US Gallons **BTR-145** (20.3 x 37.4) - 3.25 US Gallons

BTR-200 (23.0" x 40.5") - 5.5 US Gallons

STEP 3. Manually Regenerate the Valve

- 3a. Open the inlet on the bypass valve slowly and allow water to enter the unit. (The outlet of the bypass should remain closed to prevent any fines or debris from entering the plumbing system. Allow all air to escape from the unit before turning the water on fully then allow water to run until the drain water appears to be clear of any fines or color.
- 3b. Plug in the valve. Allow the valve to continue its cycles until complete and back in service. Allow the valve to stay in each position for 2 - 3 minutes to purge air from the system and the valve. Failure to properly purge the system may result in unsatisfactory performance. This process can be performed more than once if necessary to purge air and color or fines from the system before finishing start up. Once the system is purged properly you can open the outlet of the bypass valve. Because your plumbing system has been disturbed it is advisable to remove screens from faucets and flush all lines until clear. **See Plumbing System Clean-Up on page 19.**

STEP 4. PROGRAMMING YOUR CONDITIONER

This unit is factory set for the correct size, you are required to program the date, the time, the number of people in the home and the correct hardness setting.

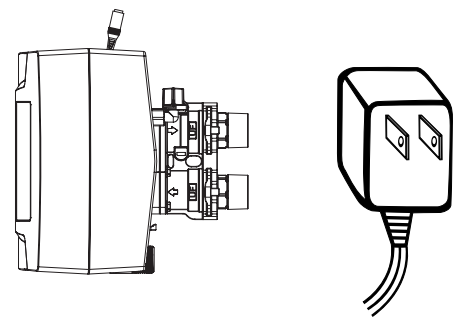

Key Pad Configuration

MENU BUTTON

The function of this key is to enter the level one programming mode where the valve settings can be adjusted.



MENU



SET

UP / DOWN

These buttons are used to increase or decrease the value of the settings while in the programming mode.



+



-

SET BUTTON

This button has two functions. The first is to initiate a manual regeneration by holding the button for 3 or more seconds. The second function is while in programming mode, pressing this key allows the user to change the value of each setting.

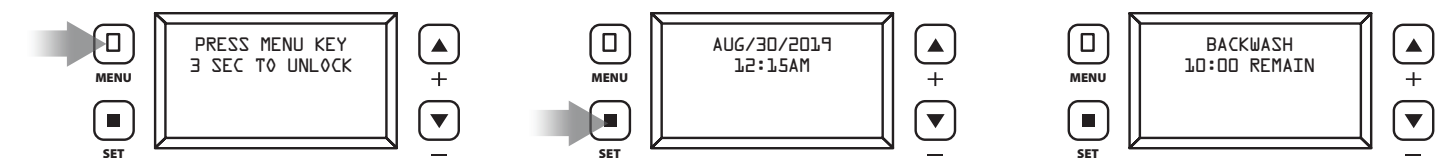
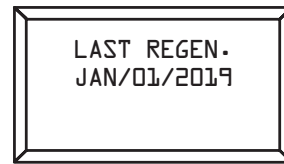

1. The display will read "PRESS MENU KEY 3 SEC TO UNLOCK".
2. After 3 seconds, the display will be beep confirming unlock.

3. Press and hold SET to start Manual Regeneration process

4. The display will read time remaining. ALLOW TO FINISH FULL CYCLE.

Please call Canature WaterGroup before attempting to change any Level 2 values as this can affect the performance of your unit. (See page 40 for Level 2 Programming)

STARTUP & PROGRAMMING (CONTINUED)

4. Manually Regenerate the Valve (Continued)

- 4a. Open the inlet on the bypass valve slowly and allow water to enter the unit. (The outlet of the bypass should remain closed to prevent any fines or debris from entering the plumbing system. Allow all air to escape from the unit before turning the water on fully then allow water to run until the drain water appears to be clear of any fines.
- 4b. Plug in the valve. Allow the valve to continue its cycles until complete and back in service. Do not manually shorten this cycle as it is critical to have the valve go through all cycles normally to purge all air from the control valve for the upflow injection system to work correctly.
- 4c. The Valve is already programmed from factory. Please set up date and time of day and feedwater hardness as shown below:

NOTE All units are factory programmed for the correct size and regeneration cycle, alteration should only be done by a factory trained technician or after consultation with one of our technical representatives if you have any questions please call: 1-877-288-9888**

5. Power and Program Valve

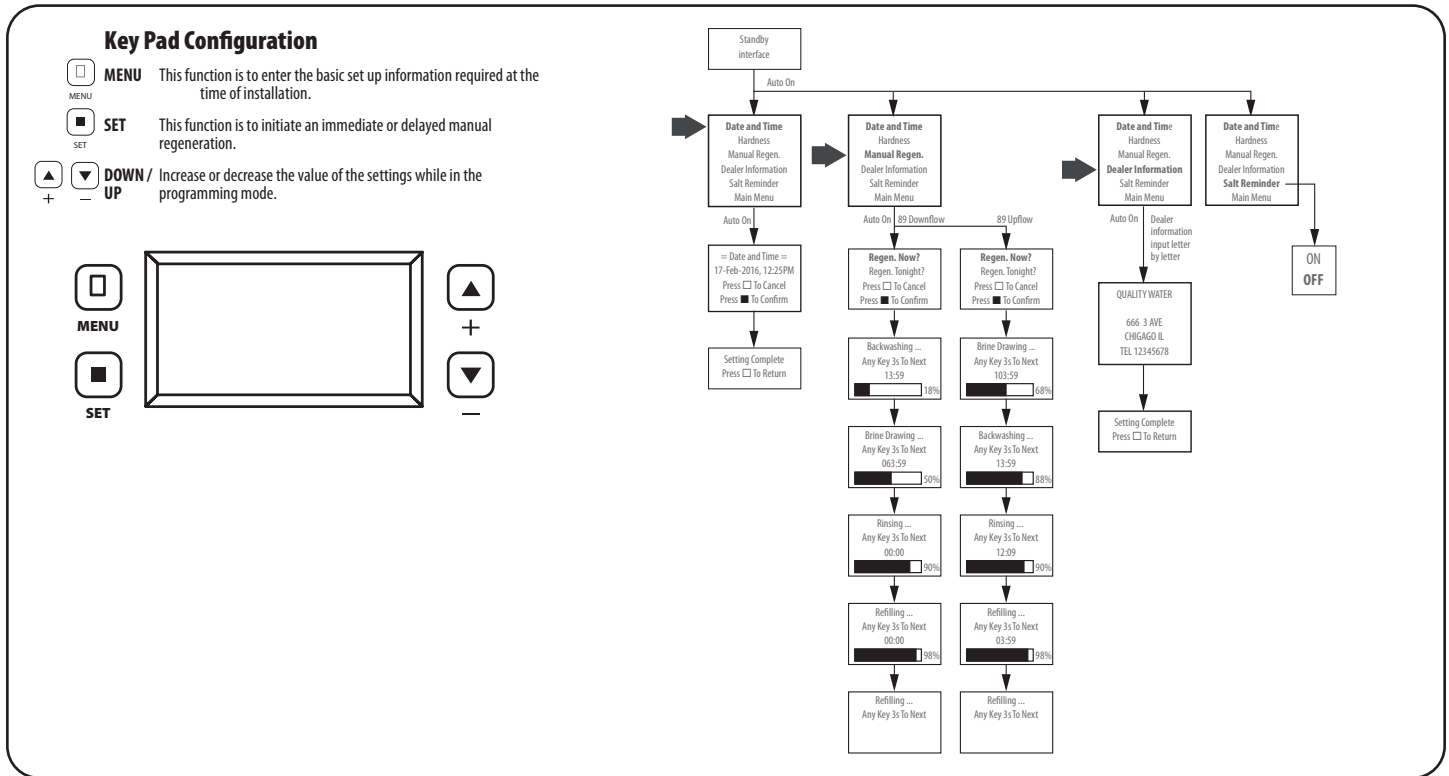

STARTUP & PROGRAMMING (CONTINUED)

*6 Add Salt to the Brine Tank/Cabinet

Put 40 kgs of crystal water conditioner salt in the brine tank. The unit will automatically fill the water to the correct level when it regenerates.

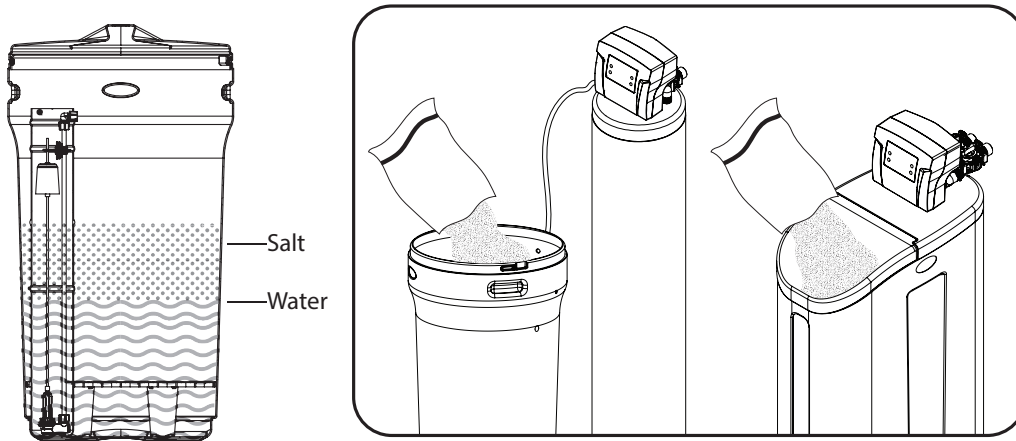

Start up and programming complete. Unit is now operational.

NOTE

NEW SOUNDS

You may notice new sounds as your water conditioner operates. The regeneration cycle lasts approximately 1.5 hours to 3.0 hours depending on the specific model. During this time, you will be able to hear water running intermittently to the drain, depending on proximity of the unit to sleeping area and time of regeneration.

*NOTE

RESIN CLEANER

An approved resin cleaner **MUST** be used on a regular basis if your water supply contains iron.

See page 28 - Res-Up® Feeder Installation Instructions

PLUMBING SYSTEM CLEAN-UP

The following procedures are guidelines only but have proven successful in most instances. Under no circumstances should any procedure outlined below be followed if contrary to the appliance manufacturer's instructions. Should there be any questions concerning the advisability of performing a procedure, it is strongly recommended the manufacturer's authorized service outlet be consulted prior to performing the procedure.

Water Heater

If the water heater has been exposed to both iron and hardness for a long period of time, replacement of the heater tank may be the only practical solution to prevent continued staining originating from this source. After completing the installation of the conditioner, clean the water heater by following these instructions:

1. Shut off energy supply to water heater and close heater inlet water valve.
2. Drain hot water tank completely. Open inlet water valve allowing heater tank to be refilled with iron-free water. Continue flushing until water runs clear to drain.
3. If, after approximately 30 minutes flushing, water does NOT clear, terminate flushing operation. Refill hot water heater with water and pour approximately 1/2 gallon of household bleach into top of heater tank. Allow bleach solution to stand in tank for 20 to 30 minutes. Flush tank.

NOTE

If water does not clear in approximately 10 minutes, water heater should probably be replaced.

Dishwasher

Consult owners' handbook and follow manufacturer's instructions.

Toilet Flush Tanks

Prior to commencing installation of the conditioner system, pour 4 to 6 ounces of resin mineral cleaner Pro-Rust Out or other suitable cleaner such as CLR that contains a mild acid into flush tanks and bowls and let stand. When installation is completed, flush toilets several times with conditioned water. If stains or deposits return check that lines are connected to treated water. Repeat procedure until clear. again until water is clear at drain. Turn energy supply on.

MAINTENANCE INSTRUCTIONS AND SCHEDULE

Service Schedule

- The seals and spacers along with the piston assembly should be inspected/cleaned or replaced every year depending on the inlet water quality and water usage. See inspection and replacement of **Piston Assembly and Seal and Spacer Kit, page 29**.
- The injectors should be cleaned/inspected or replaced every year depending on the water quality and use. See **Clean Injector Assembly, page 29**.
- The media should be replenished or replaced depending of inlet water quality and water consumption. Check with your water treatment expert on the media bed change frequency.
- Maintenance Kit (60010307) should be used for servicing control on an annual basis. The maintenance kit consists of piston assembly, seals and spacers, injectors.

Maintenance of your new water conditioner requires very little time or effort but it is essential. Regular maintenance will ensure many years of efficient and trouble free operation.

FAILURE TO FOLLOW BASIC MAINTENANCE SCHEDULE WILL RESULT IN THE UNIT FAILING TO OPERATE PROPERLY AND VOID YOUR WARRANTY.

Bridging

Humidity or the wrong type of salt may create a cavity between the water and the salt. This action, known as "bridging", prevents the brine solution from being made, leading to your water supply being hard.

If you suspect salt bridging, carefully pound on the outside of the plastic brine tank or pour some warm water over the salt to break up the bridge. This should always be followed up by allowing the unit to use up any remaining salt and then thoroughly cleaning out the brine tank. Allow four hours to produce a brine solution, then manually regenerate the conditioner .

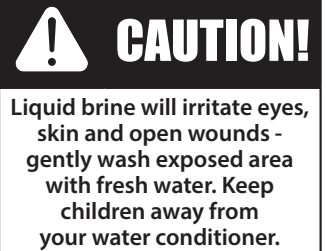
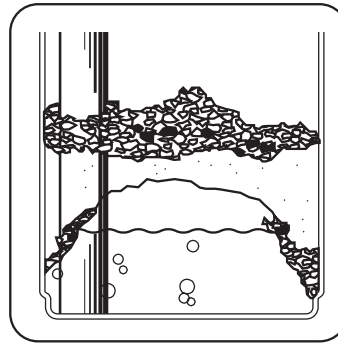

Cleaning of your Brine / Salt tank

Salt tanks will build up sludge (undissolved salt) in the bottom of them that will continue to increase as time goes by. Every 2 - 3 years the salt tank should be cleaned out completely and re started using the original start up instructions.

Never subject your conditioner to freezing, vacuum or to temperatures above 43°C (110°F).

Checking the Salt Level

Check the salt level monthly. Remove the lid from the cabinet or brine tank, make sure salt level is always above the brine level.

Add Salt to the Brine Tank/Cabinet

Put 40 kgs of crystal water conditioner salt in the brine tank. The unit will automatically fill the water to the correct level when it regenerates. Use only clean salt labeled for water conditioner use, such as crystal, pellet, nugget, button or solar. The use of rock salt is discouraged because it contains insoluble silt and sand which build up in the brine tank and can cause problems with the system's operation. Add the salt directly to the tank, filling no higher than the top of the brine well.

NOTE :THE WATER LEVEL SHOULD BE BELOW THE SALT LEVEL ALL THE TIME

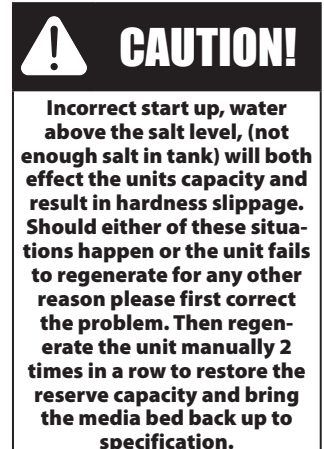
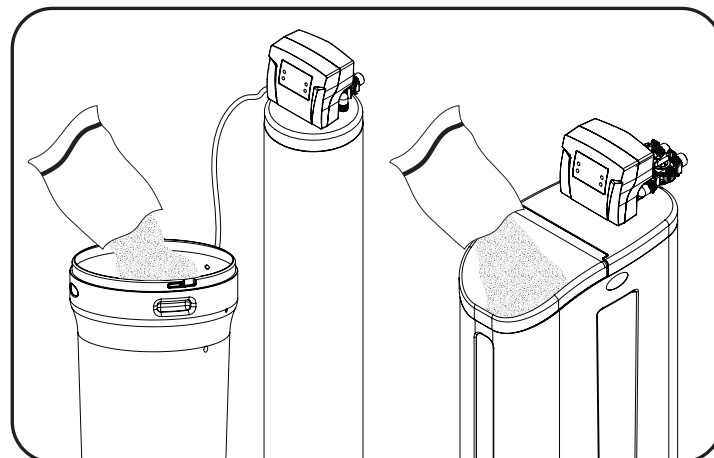
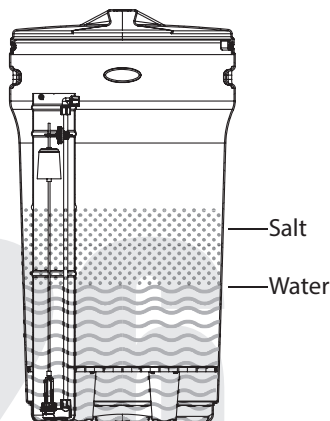

MAINTENANCE INSTRUCTIONS AND SCHEDULE

Care of Your Conditioner

To retain the attractive appearance of your new water conditioner, clean occasionally with a mild soap solution. Do not use abrasive cleaners, ammonia or solvents. Never subject your conditioner to freezing or to temperatures above 43°C (110°F).

Resin Cleaner

An approved resin cleaner **MUST** be used on a regular basis if your water supply contains iron. The amount of resin cleaner and frequency of use is determined by the quantity of iron in your water (consult your local representative or follow the directions on the resin cleaner package).

RES-UP® FEEDER INSTALLATION INSTRUCTIONS (OPTIONAL)

Res-Up Feeders attach to your brine tank and automatically dispense the Res-Up cleaner into the brine solution where it cleans the resin during the regeneration cycle.

The feeder hooks onto the tube inside your brine tank and you just pour some chemical in it and your water conditioner should last significantly longer. A res-up feeder is essential if your raw water contains measurable amounts of iron.

Res-up Feeder Bottle (Chemical sold Separately)
The 12 cc feeder (Part # 33010) is for conditioners up to 64,000 grains (2 ft3 of resin).
The 30 cc feeder (Part # 33018) is for larger conditioners over 64,000 grains.
Pro-Res Care Chemicals
Item #45147 Pro-ResCare - Gallon
Item #45148 Pro-ResCare - Quart

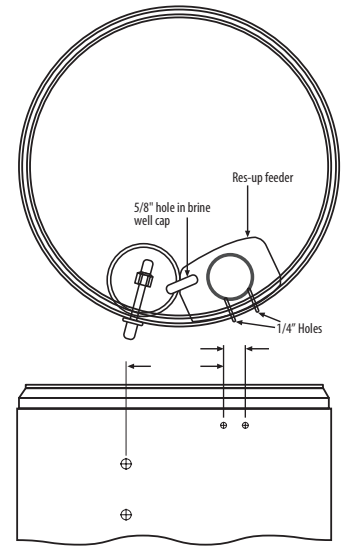

Install Resup Feeder

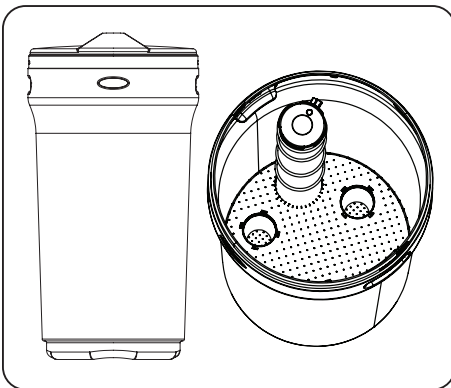

1. Install the grid and brine well inside the tank.

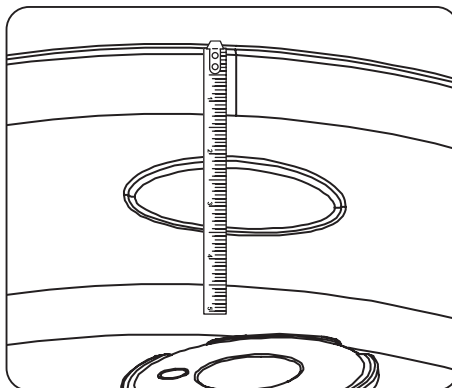

2. Measure 2 inches from the top of the tank beside the oblong molding.

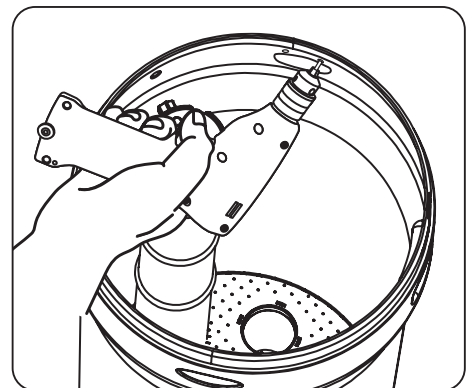

3. Mark the location of the holder and drill.

Res-Up® Feeder Installation Instructions Round Brine Tank - continued

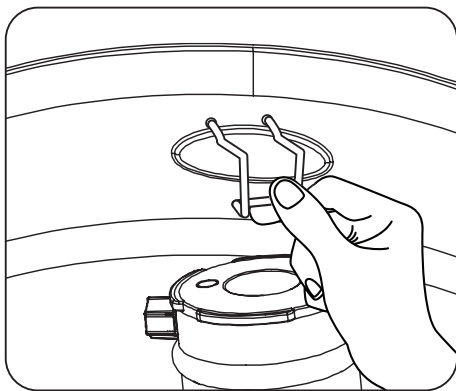

4. Install the holder and the Res Care Solution

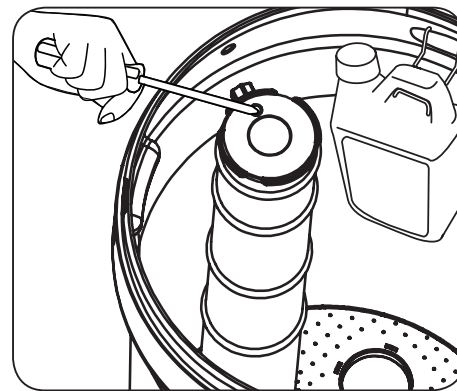
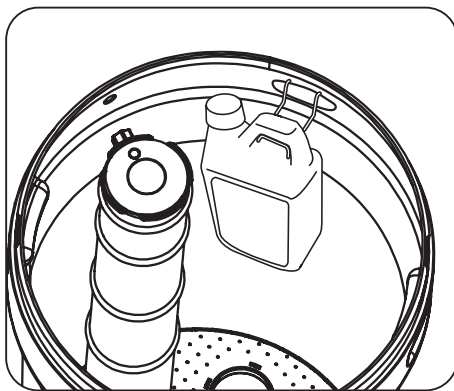

5. Take off the small hole cover on the Brine Well lid.

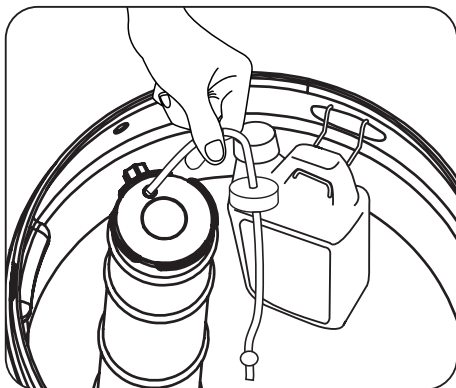

6. Take off the cover of the Res care bottle . Insert the wick, making sure it touches the bottom of the bottle. Insert the other end of the tube completely into the hole in the brine well cap. Automatic feeding will start in a few hours.

Install Resup Feeder - Square Brine Tank

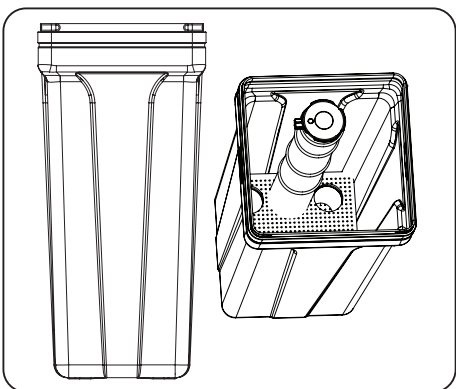

1. Install the grid and brine well inside the square tank.

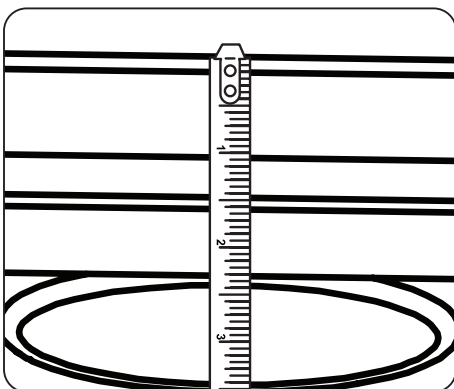

2. Measure 2 inches from the top of the tank beside the oblong molding.

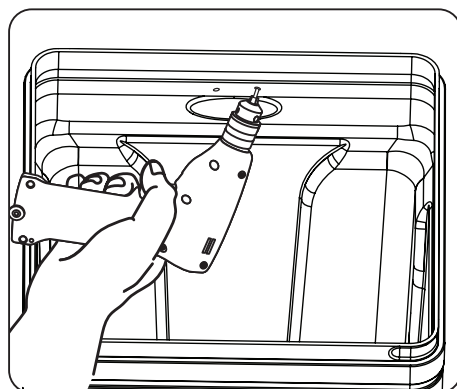

3. Mark the location of the holder and drill.

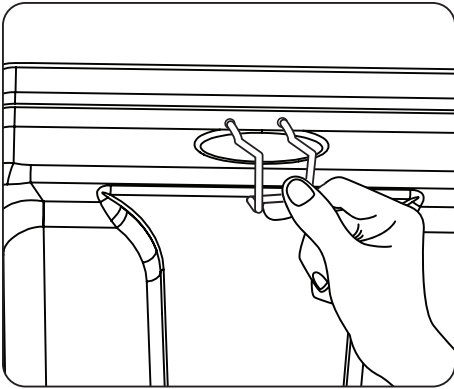

4. Install the holder and the Res Care Solution

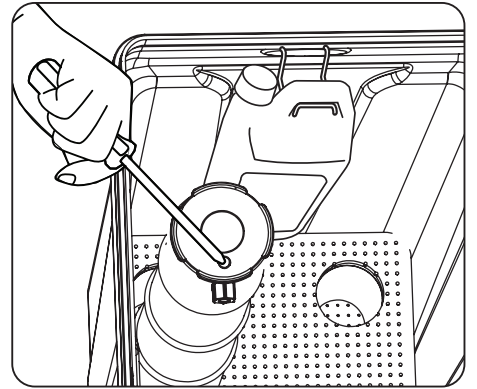
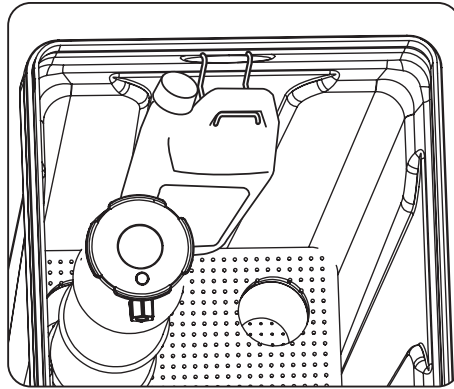

5. Take off the small hole cover on the Brine Well lid.

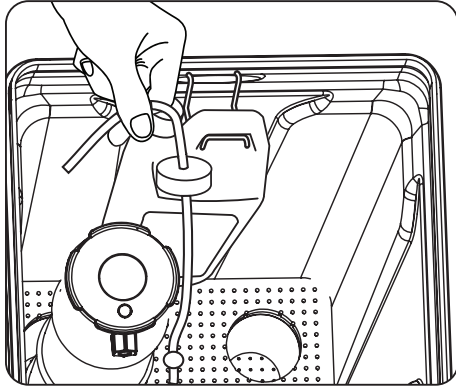

6. Take off the cover of the Res care bottle . Insert the wick, making sure it touches the bottom of the bottle. Insert the other end of the tube completely into the hole in the brine well cap. Automatic feeding will start in a few hours.

SERVICING 89HE VALVE

Before Servicing

1. Turn off water supply to conditioner :
 - a. If the conditioner installation has a 3 valve bypass system first open the valve in the bypass line, then close the valves at the conditioner inlet & outlet.
 - b. If the conditioner has an integral bypass valve, put it in the bypass position.
 - c. If there is only a shut-off valve near the conditioner inlet, close it.
2. Relieve water pressure in the conditioner by stepping the control into the backwash position momentarily. Return the control to the In Service position.
3. Unplug Electrical Cord from outlet.
4. Disconnect drain line connection.

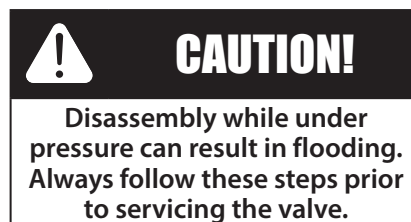

TROUBLE SHOOTING GUIDE

Problem	Possible Solutions
<p>1. CONDITIONER DELIVERS HARD WATER</p> <ul style="list-style-type: none"> A. Bypass valve is open B. No salt in brine tank C. Injector or screen plugged D. Insufficient water flowing into brine tank E. Hot water tank hardness F. Leak at distributor tube G. Internal valve leak H. Flow meter jammed I. Flow meter cable disconnected or not plugged into meter cap J. Improper programming 	<ul style="list-style-type: none"> A. Close bypass valve B. Add salt to brine tank and maintain salt level above water level C. Replace injectors and screen D. Check brine tank fill time and clean brine line flow tank control if plugged E. Make sure distributor tube is not cracked. Check O ring and tube pilot F. Make sure distributor tube is not cracked. Check O ring and tube pilot G. Replace seals and spacers and/or piston H. Remove obstruction from flow meter I. Check meter cable connection to timer and meter cap J. Reprogram the control to the proper regeneration type, inlet water hardness, capacity or flow meter size.
<p>2. CONDITIONER FAILS TO REGENERATE</p> <ul style="list-style-type: none"> A. Electrical service to unit has been interrupted B. Timer is not operating properly C. Defective valve drive motor D. Improper programming 	<ul style="list-style-type: none"> A. Assure permanent electrical service (check fuse, plug, chain or switch) B. Replace timer C. Replace drive motor D. Check programming and reset as needed
<p>3. UNIT USES TOO MUCH SALT</p> <ul style="list-style-type: none"> A. Improper salt setting B. Excessive water in brine tank C. Improper programming 	<ul style="list-style-type: none"> A. Check salt usage and salt setting B. See #7 C. Check programming and reset as needed
<p>4. LOSS OF WATER PRESSURE</p> <ul style="list-style-type: none"> A. Iron build-up in line to water conditioner B. Iron build-up in water conditioner C. Inlet of control plugged due to foreign material broken loose from pipes by recent work done on plumbing system. 	<ul style="list-style-type: none"> A. Clean line to water conditioner B. Clean control and add resin cleaner to resin bed. Increase frequency of regeneration C. Remove piston and clean control
<p>5. LOSS OF RESIN THROUGH DRAIN LINE</p> <ul style="list-style-type: none"> A. Air in water system B. Drain line flow control is too large 	<ul style="list-style-type: none"> A. Assure that well system has proper air eliminator control. Check for dry well condition. B. Ensure drain line flow control is sized
<p>6. IRON IN CONDITIONED WATER</p> <ul style="list-style-type: none"> A. Fouled resin bed B. Iron content exceeds recommended parameters 	<ul style="list-style-type: none"> A. Check backwash, brine draw and brine tank fill. Increase frequency of regeneration. Increase backwash time. B. Add iron removal filter system
<p>7. EXCESSIVE WATER IN BRINE TANK</p> <ul style="list-style-type: none"> A. Plugged drain line flow control B. Brine valve failure C. Improper programming 	<ul style="list-style-type: none"> A. Clean flow control B. Replace brine valve C. Check programming and reset as needed
<p>8. SALT WATER IN SERVICE LINE</p> <ul style="list-style-type: none"> A. Plugged injector system B. Timer not operating properly C. Foreign material in brine valve D. Foreign material in brine line flow control E. Low water pressure F. Improper programming 	<ul style="list-style-type: none"> A. Clean injector and replace screen B. Replace timer C. Clean or replace brine valve D. Clean brine line flow control E. Raise water pressure F. Check programming and reset as needed
<p>9. CONDITIONER FAILS TO DRAW BRINE</p> <ul style="list-style-type: none"> A. Drain line flow control is plugged B. Injector is plugged C. Injector screen is plugged D. Line pressure is too low E. Internal control leak F. Improper programming G. Timer not operating properly 	<ul style="list-style-type: none"> A. Clean drain line flow control B. Clean or replace injectors C. Replace screen D. Increase line pressure (line pressure must be at least 20 psi at all times) E. Change seals and spacers and/or piston assembly F. Check programming and reset as needed G. Replace timer
<p>10. CONTROL CYCLES CONTINUOUSLY</p> <ul style="list-style-type: none"> A. Timer not operating properly B. Faulty microswitches and/or harness C. Faulty cycle cam operation 	<ul style="list-style-type: none"> A. Replace timer B. Replace faulty microswitch or harness C. Replace cycle cam or reinstall

TROUBLE SHOOTING GUIDE

Problem	Possible Solutions
<p>11. DRAIN FLOWS CONTINUOUSLY</p> <p>A. Foreign material in control B. Internal control leak C. Control valve jammed in brine or backwash position D. Timer motor stopped or jammed teeth E. Timer not operating properly</p>	<p>A. Remove piston assembly and inspect bore. Remove foreign material and check control in various regeneration positions B. Replace seals and/or piston assembly C. Replace piston and seals and spacers D. Replace timer motor and check all gears for missing teeth E. Replace timer</p>
<p>12. (Error Code) (Error E1) - Electrical Trouble Shooting:</p> <p>Issue 1: When the controller is plugged, the buzzer beeps and the screen displays "System Error E1"</p> <p>Cause: The wire of micro switch is not plugged or loose.</p>	<p>Check the micro switch and connect the wire well.</p>
<p>13. (Error Code) (Error E1) - Electrical Trouble Shooting:</p> <p>Issue 2: The buzzer beeps and the screen displays "System Maintaining E1"</p> <p>Cause: The wire of micro switch is not plugged or loose..</p>	<p>Check the micro switch and connect the wire.</p>
<p>14. (Error Code) (Error E2) - Electrical Trouble Shooting:</p> <p>Issue: The buzzer beeps and the screen displays "System Error E2"</p> <p>Cause: The motor can not find its right position, micro switch or motor malfunction, automatic circuit protection action.</p>	<p>Check the current of micro switch and motor.</p>
<p>15. (Error Code) (Error E2) - Electrical Trouble Shooting:</p> <p>Issue 2: The buzzer beeps and the screen displayed " System Maintaining E2"</p> <p>Cause: The motor can not find its right position.</p>	<p>Replace Motor or PCB.</p>

THE FOLLOWING 'REPLACEMENT SECTION', PAGES 32 TO 36 CONTAIN CONTENT THAT SHOULD ONLY BE USED BY A QUALIFIED SERVICE TECHNICIAN:

TIMER REPLACEMENT

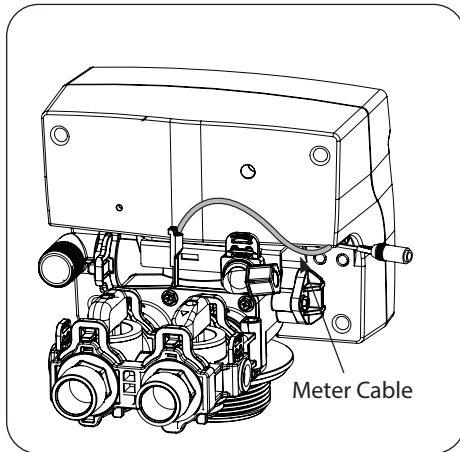

1. Disconnect the meter cable from the meter. (If flow meter is attached)

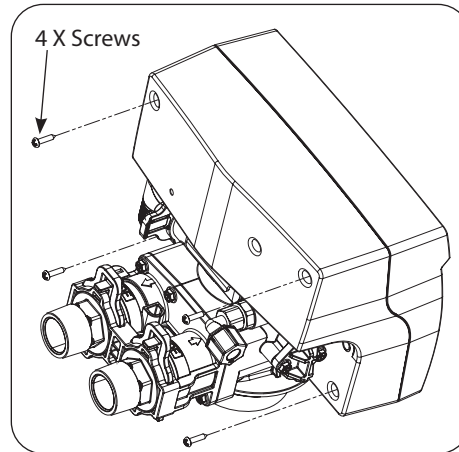

2. Remove four screws from the back of the valve cover

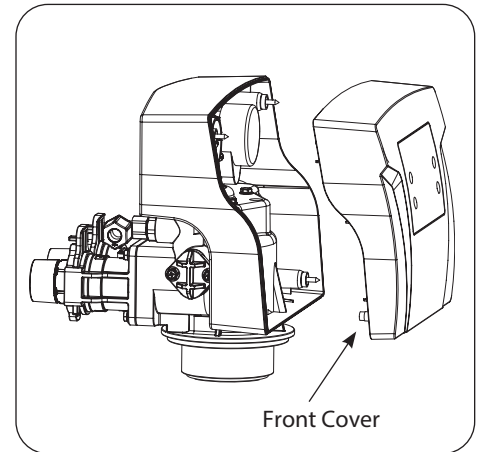

3. Remove the front cover of the valve.

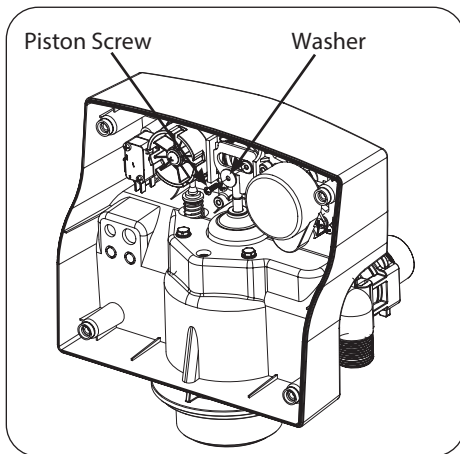

4. Remove the piston screw and washer from the piston rod.

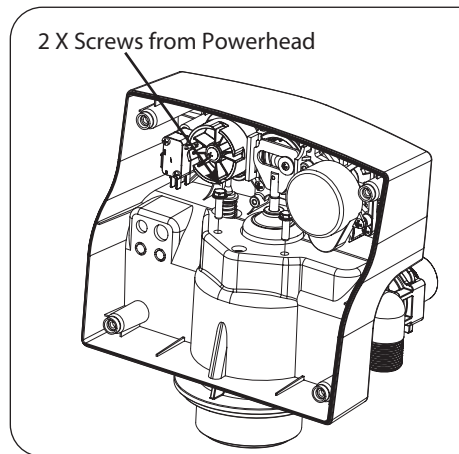

5. Remove the two screws from the powerhead as shown

6. Lift the powerhead from the valve body assembly

7. Replace the powerhead by reverse following the steps in this section

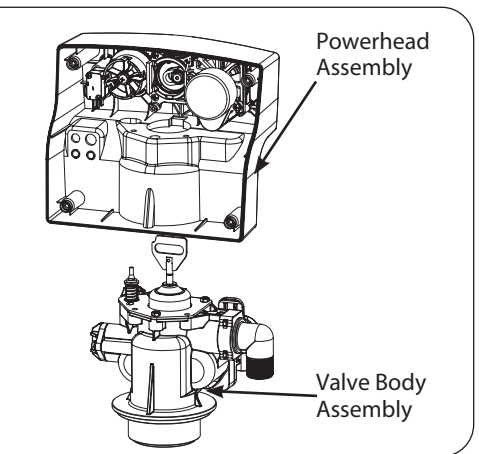

PISTON AND/OR BRINE VALVE ASSEMBLY REPLACEMENT

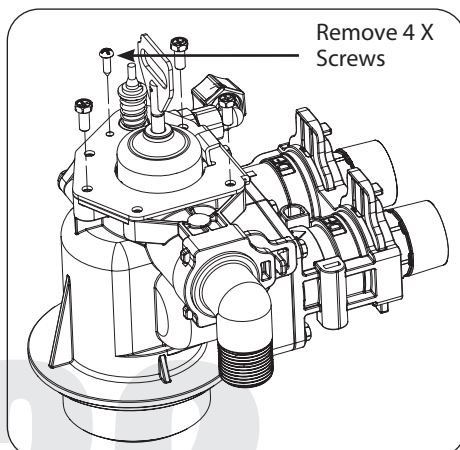

1. Follow steps 1 to 6 of timer /Powerhead replacement.

2. Remove four screws from the plate on the valve body.

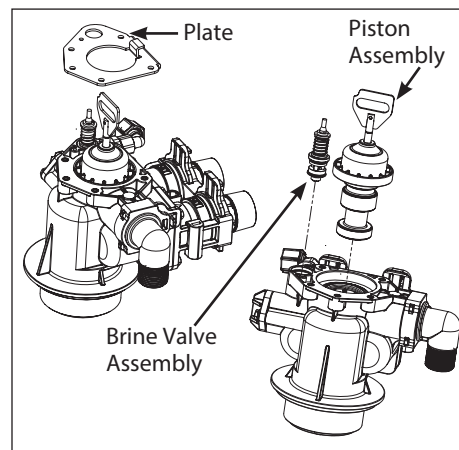

3. Remove the plate from the valve body and pull the Piston Assembly from the valve. The brine valve assembly can also be removed in this stage.

4. Remove the seal spacer assembly, grease it with silicone lubricant and put back in.

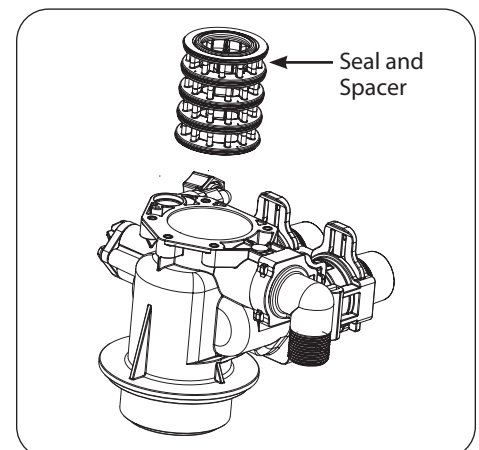

5. Replace piston assembly followed by timer assembly.

6. Replace the piston assembly and reverse following steps in this section

METER ASSEMBLY REPLACEMENT (For Models Manufactured after Valve Serial # Date of November 2015)

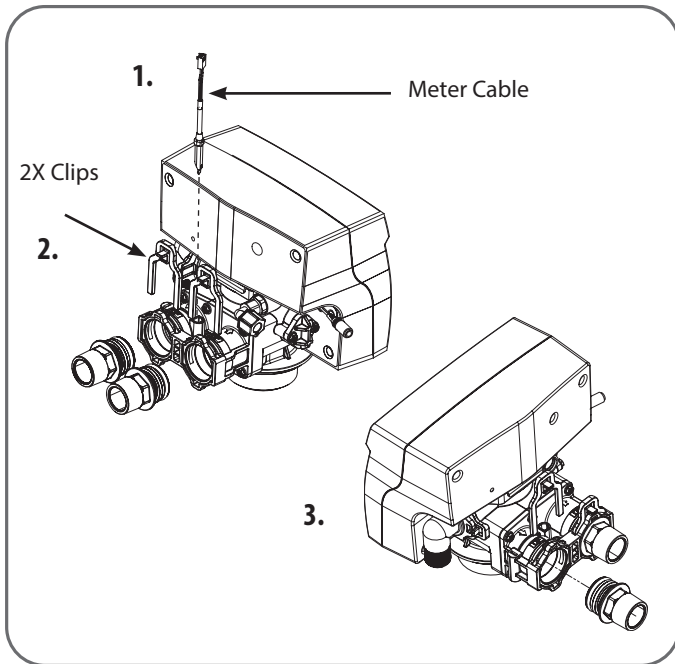

1. Disconnect the meter cable from the meter.
2. Disconnect the valve from bypass by removing clips
3. Remove the coupling adapter from the valve

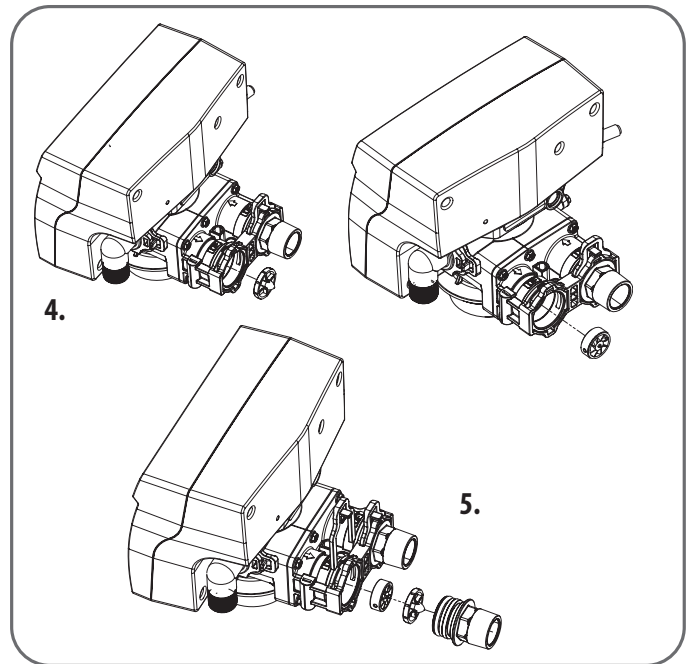

4. Remove the meter support and then the impeller out from the coupling and clean it
5. Replace meter with the help of special tool and re-assemble the removed components back in the section

METER ASSEMBLY REPLACEMENT (For Models Manufactured before Valve Serial # Date of November 2015)

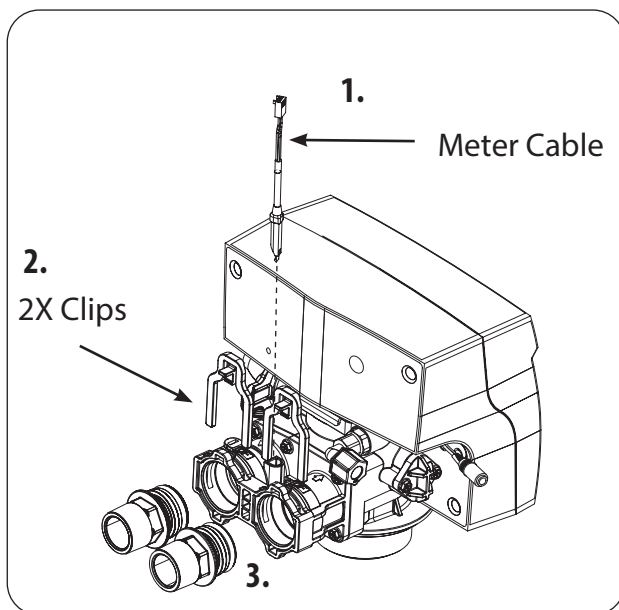

1. Disconnect the meter cable from the meter.
2. Disconnect the valve from bypass by removing clips
3. Remove the coupling adapter from the valve

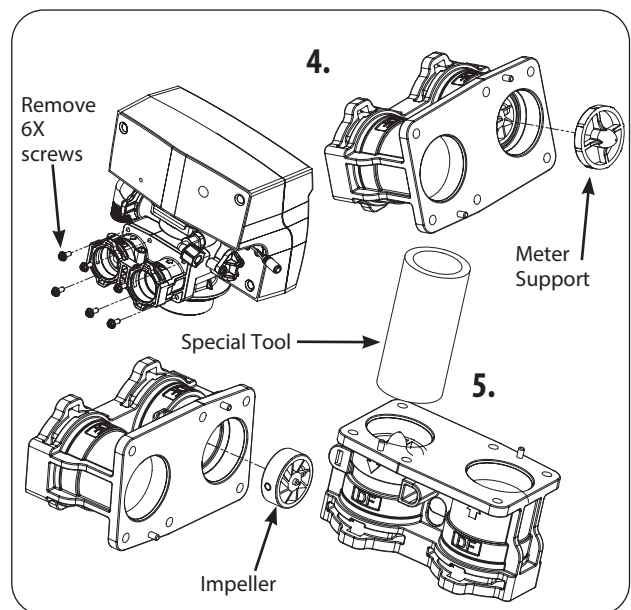

4. Remove six screws and pull out the meter support and impeller.
5. Replace meter with the help of special tool and re-assemble the removed components back in the section

REPLACING THE BYPASS AND METER CABLE

If valve is manufactured before March 20th, 2018, and customer wishes to replace or service impeller on bypass. Customer can order 60010238. If customer wishes to replace to new design, then follow the steps below.

60095101 Bypass comes with Meter and Grey Meter Cable

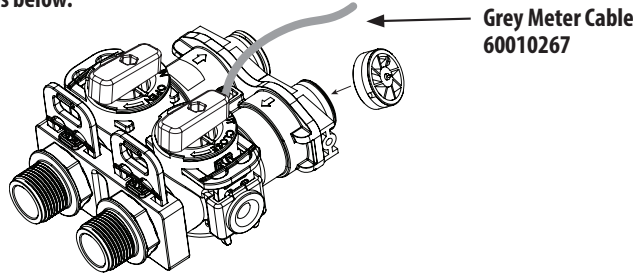

Step 1
Unplug the power from the wall socket.

Step 2*
Remove 2 screws and clips from bypass.

***NOTE**
Water to the household needs to be turned off and pressure relieved before Step 2.

Disconnect the meter cable from the bypass.

Step 3 Remove Cover.

Step 4
Disconnect the cables from the front PCB display.

Step 5
Disconnect the cables from the rear PCB display.

Cut the tie that fastens the wires

Step 6
Remove strain relief with pliers.

Step 7
Replace the old cable with the new Cable.

Step 8
Assemble the valve. Plug the power supply back into the wall socket and follow the programming shown on right:

Affects valves manufactured after March 20, 2018.
If replacing old impeller assembly to new version on Valves manufactured before March 20th 2018, programming should be adjusted on the control valve. Please see steps below:
To enter the programming press and hold the MENU button for 5 seconds to unlock the screen.
Press and hold the Up and Down Arrows.
Press the down arrow to get to METER RATIO then press SET.
Press UP or Down Arrow to choose Turbine-H and press SET.
Set as per charts on right.**

NEW

Valve Type	Unit Measure	Turbine-H	
		A	K
89 UF sSoftener	US Gallon	1.20	0.731
89 DF Softener	US Gallon	1.6	0.621
89 DF Filter	US Gallon	1.7	0.597

OLD

Valve Type	Unit Measure	Turbine-H	
		A	K
89 UF Softener	US Gallon	1.06	0.636
89 DF Softener	US Gallon	1.6	0.575
89 DF Filter	US Gallon	1.1	0.558

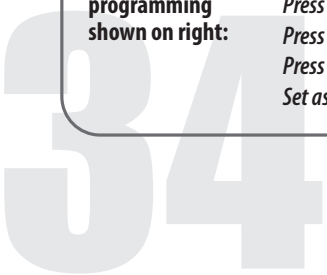

CLEAN INJECTOR ASSEMBLY

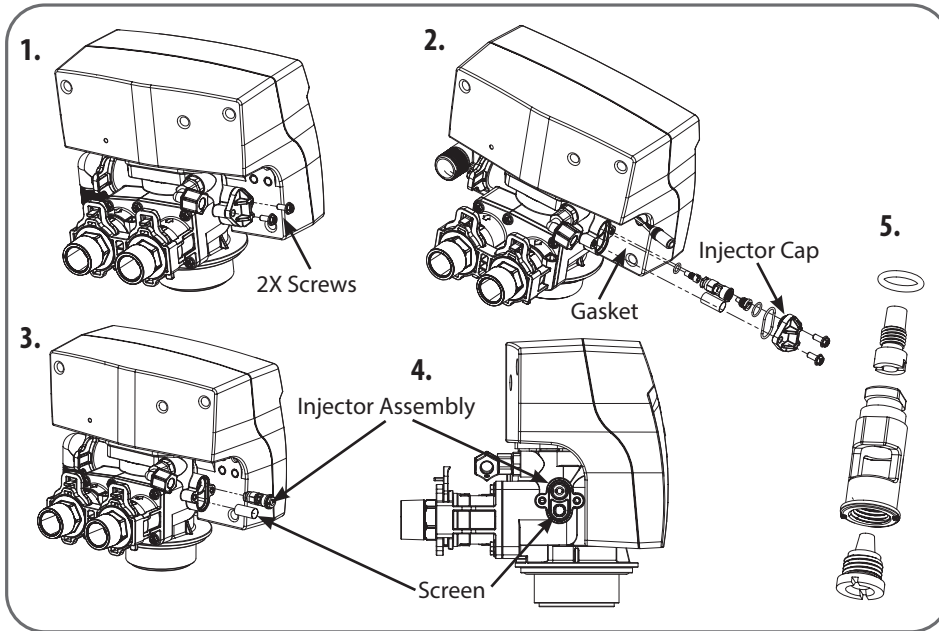

1. Remove the two screws from the injector cap
2. Pull the injector cap and gasket
3. Pull the injector assembly and Screen
4. Replace/Clean screen and injector assembly and put it back in the valve in appropriate location as shown
5. Put back the injector cap. Grease the injector assembly orings and injector cap gasket. Care should be taken to put all orings and gaskets in place and grease them so that they dont pinch

REPLACE MOTOR

1. Remove Screws from the back of the valve and pull the cover
2. Remove all connections from the circuit board
3. Remove the two screws from the motor. Remove the motor and watch for the pin under the motor.
4. Replace the motor, connections and cover

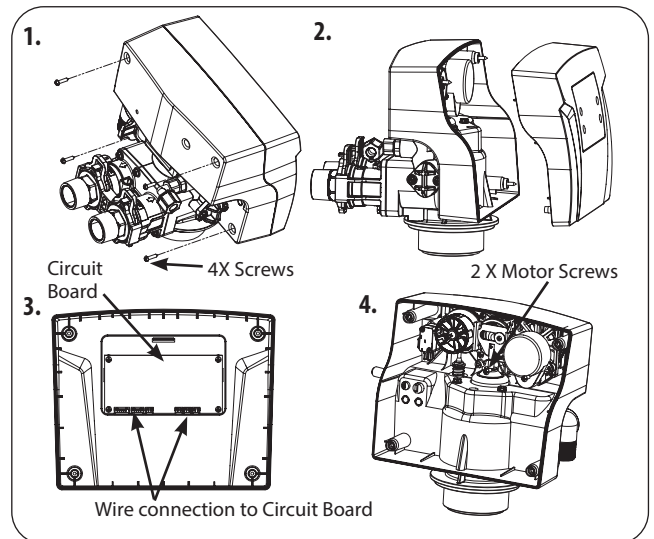
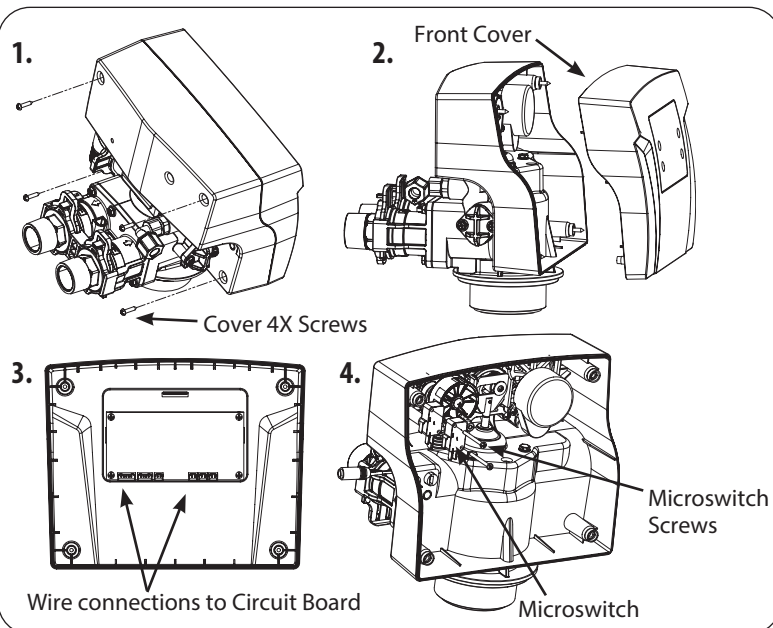

REPLACE MICROSWITCHES

1. Remove Screws from the back of the valve and pull the cover
2. Remove all connections from the circuit board
3. Remove the two screws from the microswitch
4. Replace the microswitch, connections and cover

CIRCUIT BOARD REPLACEMENT

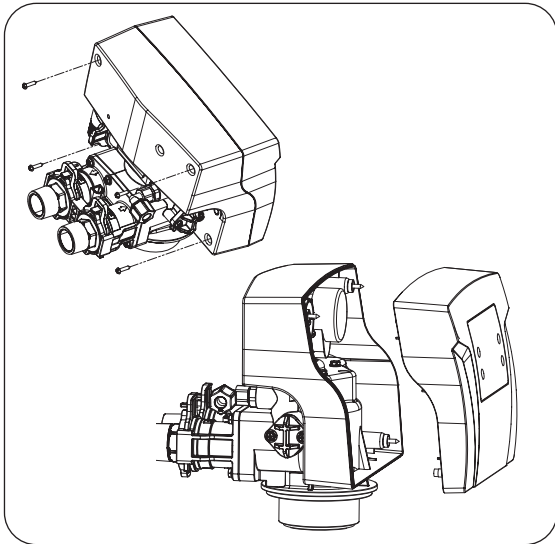

1. Remove the screws from the back of the valve and pull the front cover

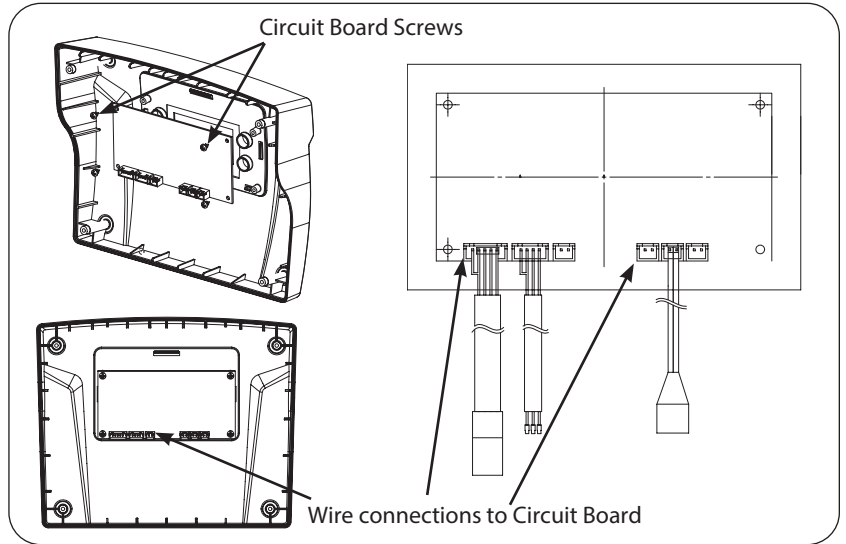

2. Remove all connections from the circuit board
3. Remove the four screws from the circuit board and pull it out

REPLACE BRINE LINE FLOW CONTROL

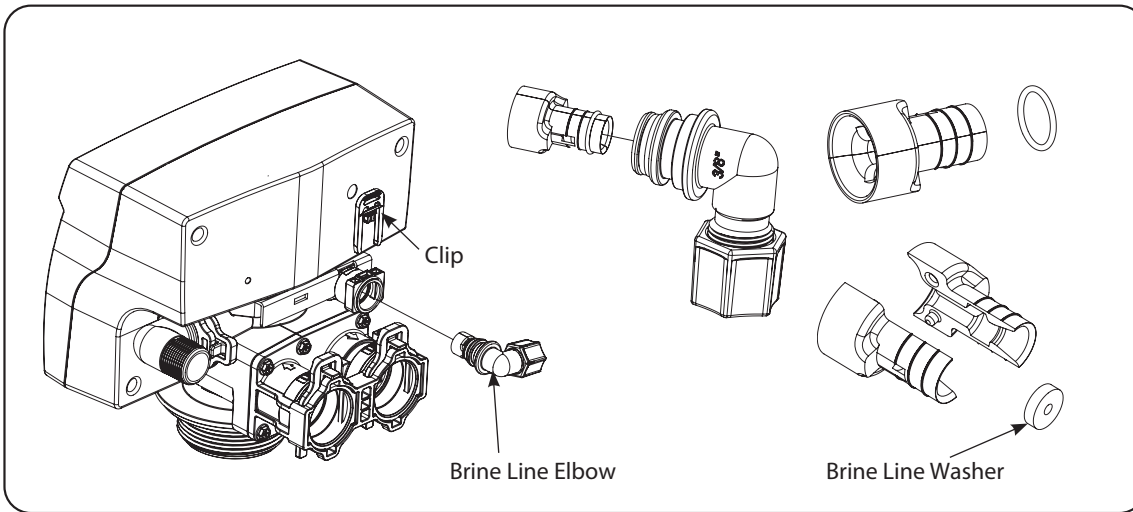

1. Pull the brine line clip and remove the brine line elbow and washer
2. Clean/replace brine line washer

REPLACE DRAIN LINE FLOW CONTROL

1. Pull the drain line clip and remove the drain line elbow and washer
2. Clean/replace drain line washer

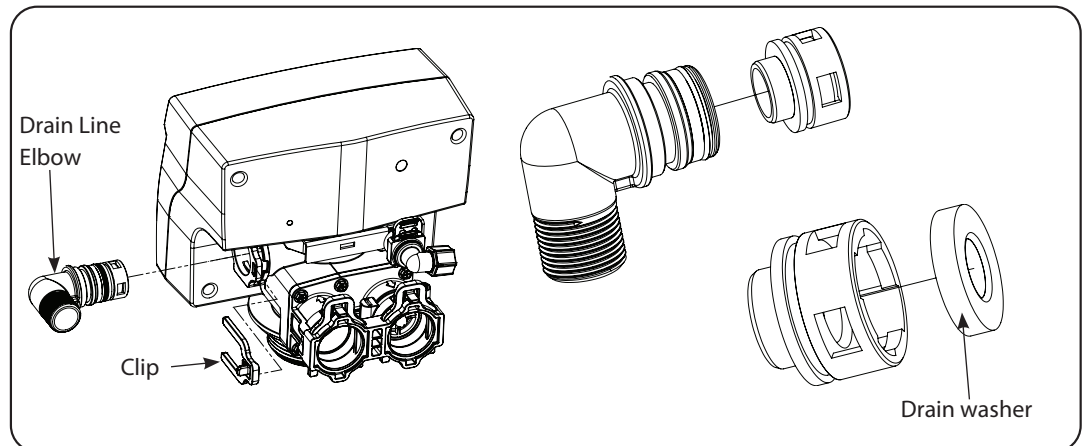

AFTER SERVICING

1. Reconnect drain line
2. Return bypass or inlet valve to normal in service position. Water Pressure will automatically build in the Softener
3. Check for leaks at all sealed areas. Check Drain seal with the control in the backwash position
4. Plug electrical cord into outlet
5. Set Time of Day and cycle the control valve manually to assure proper function. Make sure control valve is returned to the In Service position. Unit should always be manually regenerated after servicing. If the unit was not working prior to service then 2 manual regenerations should be done 24 hours apart to restore the full bed capacity.

NOTE
Be sure to shut off any bypass line.

PARTS BREAKDOWN

Control Valve

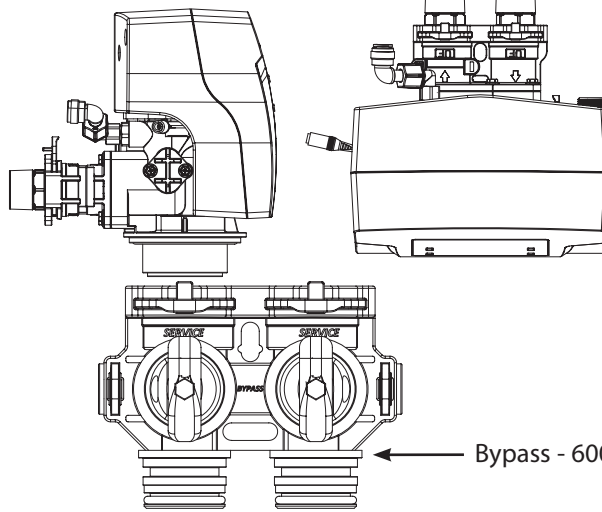
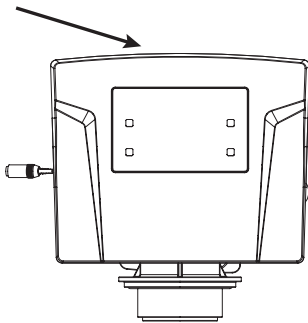

Bypass - 60010004

Upper Cone (18280)

Distributor

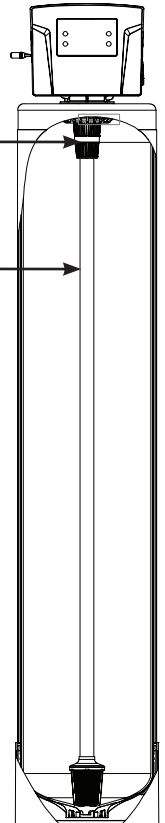

Upflow Softener

Model	Mineral Tank Size	Tank # (Natural Color)	Tank # (Black Color)	Tank # (Blue Color)	Distributor#	Valve #	Media Bed #
Softener Upflow (Single Tank)							
75	8 x 44	25010025	25010027	25010026	50010005	10010044	95600
100	9 x 48	25010034	25010036	25010035	50010005	10010044	95601
150	10 x 54	25010049	25010051	25010050	50010005	10010044	95606
200	12 x 52	25010058	25010060	25010059	50010005	10010044	95609
250	13 x 54	25010064	25010066	25010065	50010010	10010044	95610
300	14 x 65	25030001 and 50040039	Not Available	Not Available	50010010	10010044	95604
400	16 x 65	25030002 and 50040036	Not Available	Not Available	50010010	10010044	

Downflow Softener

Model	Mineral Tank Size	Tank # (Natural Color)	Tank # (Black Color)	Tank # (Blue Color)	Distributor#	Valve #	Media Bed #
Softener Downflow (Single Tank)							
75	8 x 44	25010025	25010027	25010026	50010005	10010043	95600
100	9 x 48	25010034	25010036	25010035	50010005	10010043	95601
150	10 x 54	25010049	25010051	25010050	50010005	10010043	95606
200	12 x 52	25010058	25010060	25010059	50010005	10010043	95609
250	13 x 54	25010064	25010066	25010065	50010010	10010043	95610
300	14 x 65	25030001 and 50040039	Not Available	Not Available	50010010	10010043	95604
400	16 x 65	25030002 and 50040036	Not Available	Not Available	50010010	10010043	

PARTS BREAKDOWN

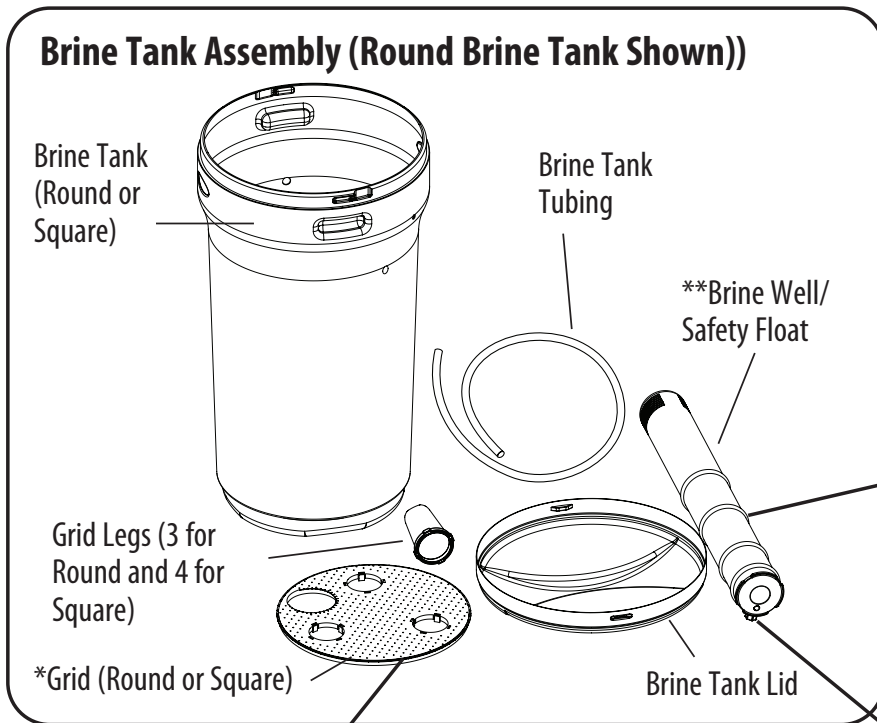
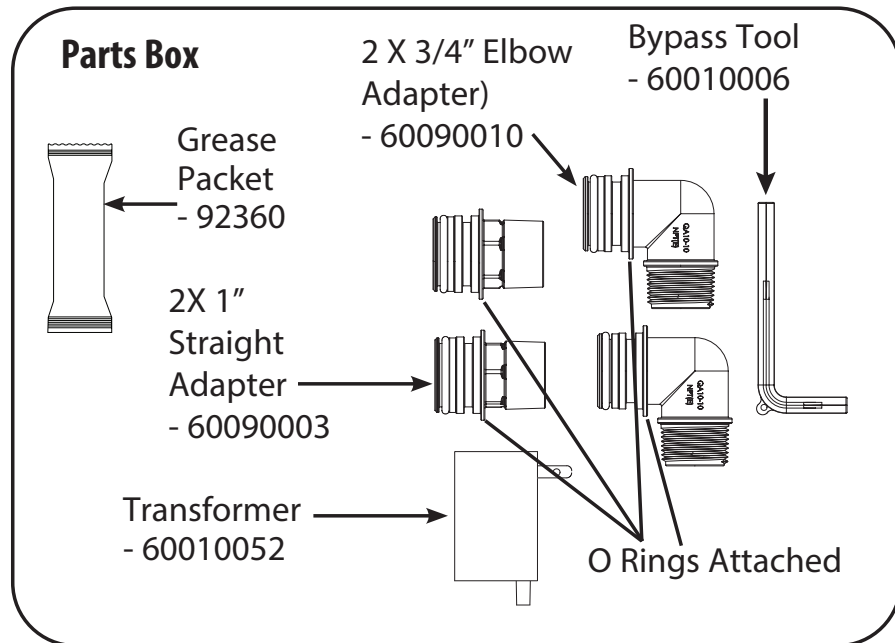

**FLOAT ASSY
 55010023 - BTR100
 55010054 - BTR145
 55010033 - BTR200

*GRID
 55010013 - For BTR 100
 55010036 - For BTR145
 55010037 - For BTR 200

IMPORTANT:

PLEASE ENSURE THE ATTACHED TUBE STIFFENER IS INSERTED INTO THE BRINE LINE BEFORE TIGHTENING THE NUT.

PARTS BREAKDOWN

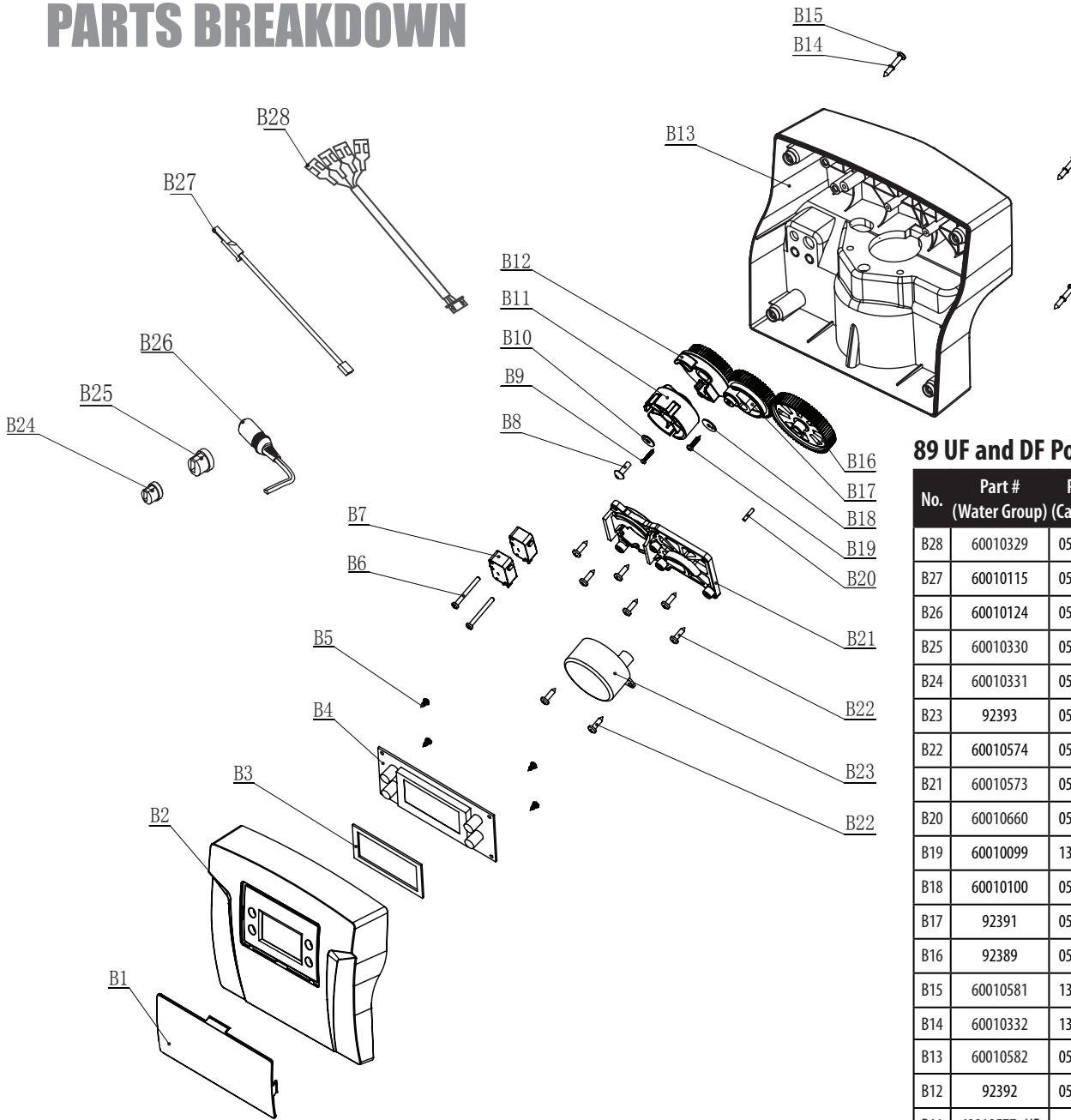

89 UF and DF Power Head Parts List

No.	Part # (Water Group)	Part # (Canature)	Description	Qty
B28	60010329	05033028	Micro Switch Cable	1
B27	60010115	05010031	Meter Cable	1
B26	60010124	05010029	Power Cable	1
B25	60010330	05010046	Meter Cable Clip	1
B24	60010331	05010035	Power Cable Clip	1
B23	92393	05056550	Motor 12VAC 3W	1
B22	60010574	05056084	Screw on Mounting Plate	8
B21	60010573	05031006	Mounting Plate	1
B20	60010660	05056098	Motor Pin	1
B19	60010099	13000426	Screw on Main Gear	1
B18	60010100	05056139	Washer on Main Gear	1
B17	92391	05031008	Main Gear	1
B16	92389	05030009	Drive Gear	1
B15	60010581	13000448	Screw on Back Cover	4
B14	60010332	13113051	Washers on Screw	4
B13	60010582	05033012	89 Back Cover(Black)	1
B12	92392	05031017	Brine Gear	1
B11	60010577 - UF 60010576 - DF	05033019	Locating wheel(UF)	1
B10	60010661	05056141B	Washer on Locating Wheel	1
B9	60010333	05033004	Screw 2.2x13	1
B8	60010575	05056166B	Screw on Locating Wheel	1
B7	60010580	05041011	Micro Switch	2
B6	60010579	13000332	Screws on Micro Switch	2
B5	60010572	13000401	Screws on PCB	4
B4	92388	05033008B	89 PCB	1
B3	60010571	05033027	PCB Absorb Shock Foam	1
B2	60010570	05033011	89 Front Cover(Black)	1
B1		05033007B	Controller Touch Panel	1

Bypass Parts List

No.	Part #	Part Description	Qty
1		89 Shaft Knob	2
2		BNT 89 Bypass Shaft	2
3		BNT 89 Bypass Body	1
4		Plug O-Ring 12.42x1.78	2
5	60010209	Bypass Plug	1
6		BNT 89 Bypass Knob Seal	8
7		Steel Retainer Ring	1
8		O-Ring 35.5x2.65	1
9		O-Ring 30x2.65	1
10	60010069	Plug Clip	1
11		O-Ring 30x3.55	1
12	92387	BNT89 Valve Clip	1

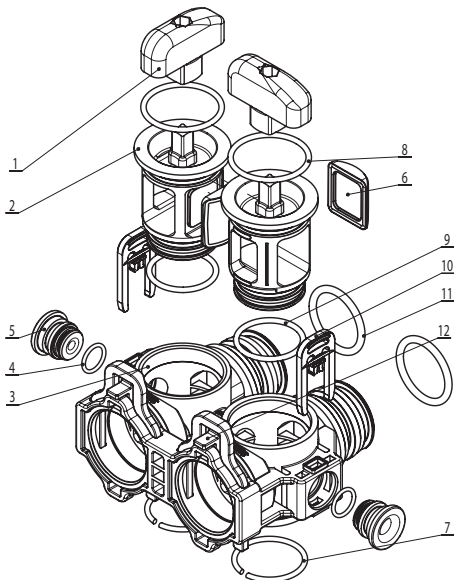

PARTS BREAKDOWN

Parts list of control valve body:

No.	Part # (Water Group)	Part # (Canature)	Description	Qty
A51	60010184	21389033	Brine Line Elbow Nut	1
A50	60010172	30020013M	Brine Line Elbow	1
A49	60010044	05056134	O-ring of Brine Line Elbow	1
A48	60010188	05031033	O-ring of BLFC Holder	1
A47	60010173	05031010M	BLFC Holder	2
A46	60010128	05056206M	BLFC(0.2GPM)(Optional)	1
A45	60010340	05033033	Brine Line Connector	1
A44	60010265	26010189	O-ring on Brine Line Connector	1
A43	60010099	13000426	Screw on Valve Bottom Connector	2
A42	60010599	07060007	Valve Bottom Connector	1
A41	60010080	26010103	Distributor O-ring	1
A40	60010598	05033021M	Central Pipe Adaptor	1
A39	60010597	26010038	O-ring of Central Pipe Adaptor	1
A38	60010077	05056063	Tank Mouth O-ring	1
A37	60010715	05033009	Screen 89 Valve	1
A36	60010595	05033020	Injector Cover	1
A35	60010341	26010101	O-ring of Injector Cover	1
A34	60010186	05031019	Big O-ring of Injector Holder	1
A33			Injector Nozzle(Optional)	1
A32	60010174	05031012M	Injector Holder	1
A31			Injector Throat(Optional)	1
A30	60010187	05031020	Small O-ring of Injector Holder	1
A29		05033010	89 Valve Body	1
A28	60010069	05056172N	Secure Clip Brine Line	1
A27	60010343	05033005B	End Plug Retainer	1
A26	60010076	05056088	Valve Body Connect Screws	2
A25	60010075	05056087	End Plug Retainer Screws	3
A24	60010574	05056084	Screw 3.5x13	1
A23	60032	05056180M	Brine Valve Injector Stem Assembly	1
A22		05033015	Spacer-89 Valve	8
A21		05033006	Seal-89 Valve	5
A20			Down Flow Piston-89 Valve	1
A19			92384 - UP PISTON ASSY	1
A18	92383 - DF PISTON ASSY		92385 - FILTER PISTON ASSY	1
A17	92384 - UP PISTON ASSY		End Plug-89 Valve	1
A16	92385 - FILTER PISTON ASSY		Piston Rod-89 Valve	1
A15			Piston Assembly-89 Valve(DF)	1
A14			DLFC(2.4GPM)(Optional)	1
A13	60095694	05040030M	DLFC Holder	1
A12	60010211	05056121	O-ring on Drain Elbow	1
A11	60010253	05040130M	Drain Elbow 3/4" NPT	1
	60010254	05040131M	Drain Elbow 1" NPT	1
A10	60010227	05040018M	Secure Clip of Drain Line	1
A9	60010585	05005636M	Big O-ring of Adaptor Coupling	2
A8			Adaptor Coupling	2
A7			Small O-ring of Adaptor Coupling	2
A6	92387	05033022M	Adaptor Secure Clip	2
A5	60010589	05033013	89 Valve Connector	1
A4	60010596	05056508	Screws of Valve Connector	8
A3	60010238	02170055	Impeller Assembly	1
A2		05010019	Bush	2
A1	60010587	05010077	Impeller Holder	1

Seal and Spacer Kit 92382

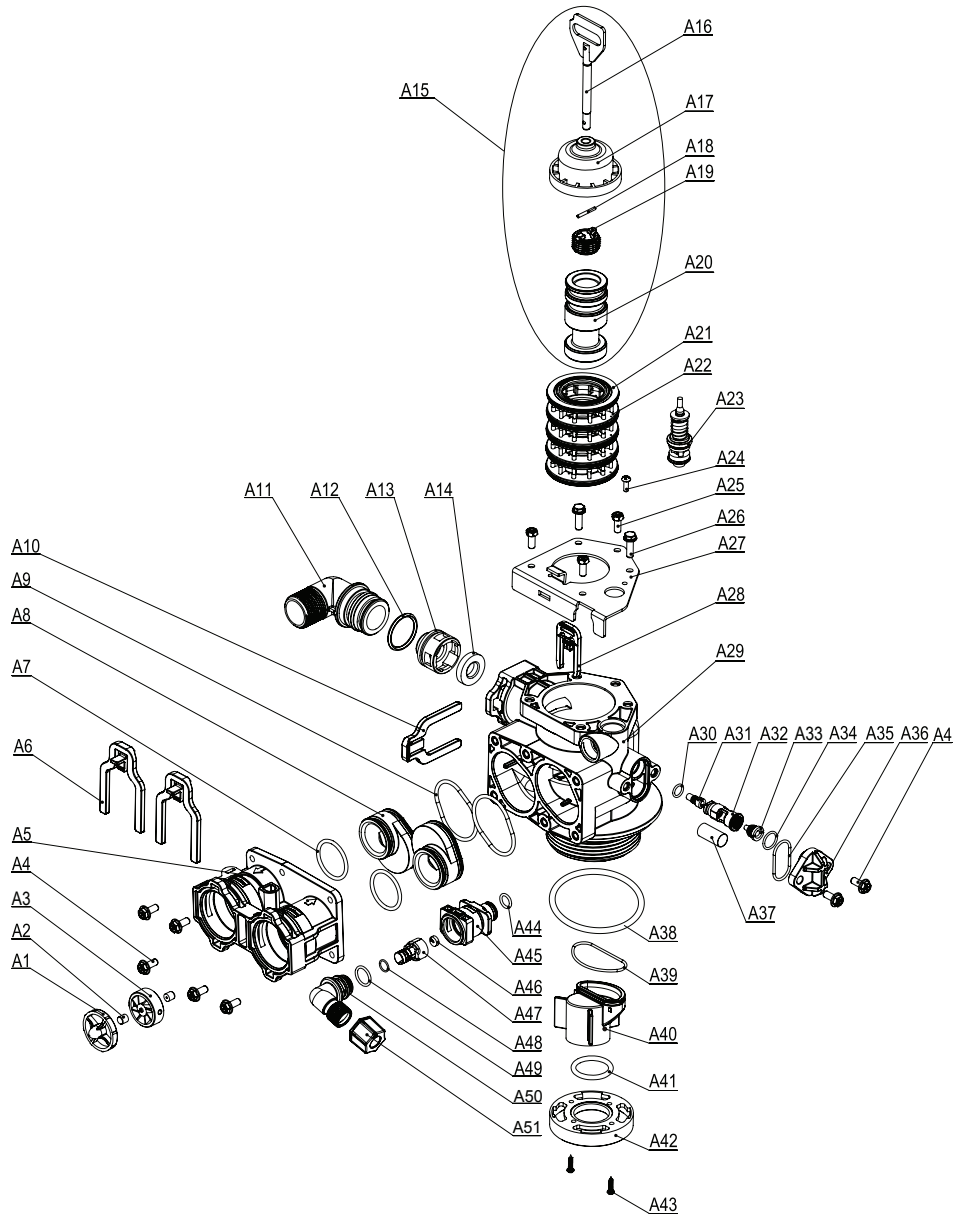

Item #s For All Injector Assemblies and Brine Line and Drain Line Washers

	Part #	Part Description	Part #	Part Description
Injector Assemblies	60010110	BLFC BUTTON #2 0.3GPM A32	60010613	INJECTOR SET #3 YELLOW THROAT
	60010082*	BLFC BUTTON #2 0.7GPM A32	60010614	NOZZLE #3 YELLOW THROAT
	60010128	BLFC BUTTON 0.2GPM	60010685	INJECTOR SET #4 GREEN THROAT
	60010601	INJECTOR SET #0000 BLACK THROAT	60010686	NOZZLE #4 GREEN THROAT
	60010602	NOZZLE #0000 BLACK THROAT	12052	1.4 GPM DLFC WASHER
	60010603	INJECTOR SET #000 GREY THROAT	12053	2.0 GPM DLFC WASHER
	60010604	NOZZLE #000 GREY THROAT	60010140	#45 5.0GPM
	60010605	INJECTOR SET #00 VIOLET THROAT	60010142	#75 7.0 GPM
	60010606	NOZZLE #00 VIOLET THROAT	60010143	#1 8.0 GPM
	60010607	INJECTOR SET #0 RED THROAT	60010144	#2 11.0 GPM
	60010608	NOZZLE #0 RED THROAT	60010145	#3 14.0 GPM
	60010609*	INJECTOR SET #1 WHITE THROAT	60010146	#4 17.0 GPM
60010610*	NOZZLE #1 WHITE THROAT	60010147	#5 21.0 GPM	
60010611	INJECTOR SET #2 BLUE THROAT	60010148	#6 24.0 GPM	
60010612	NOZZLE #2 BLUE THROAT			

* Default

PARTS BREAKDOWN

DLFC PART # for 89 VALVE

No.	Part #	Part Description	Qty
1	60095720	BNT95DLFC-0(4.0 GPM)	1
2	60010143	BNT95DLFC-1(7.0GPM)	1
3	60010144	BNT95DLFC-2(11.0GPM)	1
4	60010145	BNT95DLFC-3(14.0GPM)	1
5	60010146	BNT95DLFC-4(17.0GPM)	1
6	60010147	BNT95DLFC-5(21.0GPM)	1
7	60095692	BNT95DLFC-6(24.0GPM)	1
8	60095721	BNT95DLFC-1S(2.4GPM)	1
9	60095722	BNT95DLFC-2S(3.5GPM)	1
10	60095723	BNT95DLFC-3S(4.5GPM)	1
11	60010140	BNT95DLFC-4S(5.0GPM)	1
12	60095724	BNT95DLFC-5S(6.0GPM)	1
13	60095725	BNT95DLFC-6S(6.0GPM)	1
14	60010142	BNT95DLFC-7S(7.0GPM)	1

BLFC PART # for 89 VALVE

No.	Part #	Part Description	Qty
1	60010128	BNT95BLFC (0.2 GPM)	1
2	12053	BNT95BLFC-1(2.0 GPM)	1
3	60010162	BNT95 BLFC-7(1.35 GPM)	1

INJECTOR PART # for 89 VALVE

No.	Part #	Part Description	Qty
1	60010601	INJECTOR THROAT(BLACK 0000#)	1
2	60010602	INJECTOR NOZZLE(BLACK 0000#)	1
3	60010603	INJECTOR THROAT(GREY 000#)	1
4	60010604	INJECTOR NOZZLE(GREY 000#)	1
5	60010605	INJECTOR THROAT(PURPLE 00#)	1
6	60010606	INJECTOR NOZZLE (PURPLE 00#)	1
7	60010607	INJECTOR THROAT(RED 0#)	1
8	60010608	INJECTOR NOZZLE(RED 0#)	1
9	60010609	INJECTOR THROAT (WHITE 1#)	1
10	60010610	INJECTOR NOZZLE (WHITE 1#)	1
11	60010611	INJECTOR THROAT(BLUE 2#)	1
12	60010612	INJECTOR NOZZLE(BLUE 2#)	1
13	60010613	INJECTOR THROAT(YELLOW 3#)	1
14	60010614	INJECTOR NOZZLE(YELLOW 3#)	1

**No 10 and 11 Injector
Parts Apply to A10
Models**

PARTS BREAKDOWN

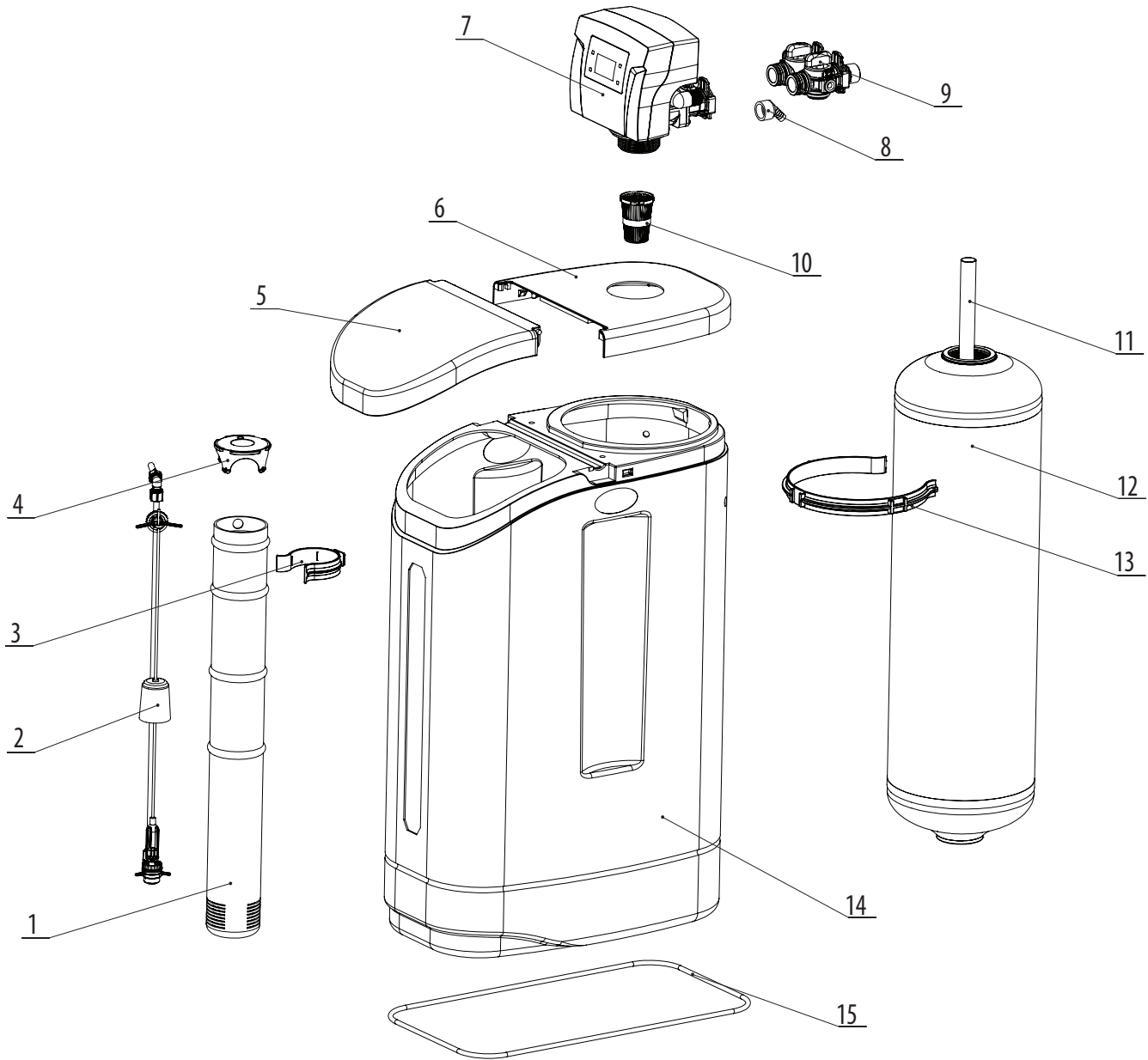

Cabinet Parts List

No.	Part #	Description	Qty
15		Trim Strip	1
14		Softener Cabinet(Grey)	1
13	60010361	Pressure Tank Clamp	1
12	25020019	TANK ASSY 935 NAT	1
	25020020	TANK ASSY 1035 NAT	
11	50010020	Distribution Assy-1035	1
10	18280	Top Cone	1
9	60010004	Bypass Valve Assy	1
8	60010255	Hose Barb	1
7		89(UF) Control Valve(Black)	1
6	55010031	Softener Low Cover	1
5	55010032	Softener Salt Lid	1
4	55020002	Brine Well Cap	1
3	60010362	Brine Well Clamp	1
2	55010023	0435 Brine Valve	1
1	55010010	0435 Brine Well	1

MASTER PROGRAMMING GUIDE

Below is how the settings are set at factory:

Upflow Valve Programming (Models 89UF)

PRESS '+' AND '-' FOR 8 SECONDS							PRESS MENU KEY AND SCROLL TO 'MAIN MENU'. THEN PRESS 'SET' TILL IT BEEPS. SCROLL TO ADVANCED MENU									PRESS MENU KEY AND SCROLL TO 'MAIN MENU'. THEN PRESS 'SET' TILL IT BEEPS					VALVE SETTINGS				
MODELS	LANGUAGE	REGION	VALVE	METER RATIO	SALT VS EFFICIENCY	AUTO CALCULATION	RESIN VOLUME	REFILL RATE	REGEN. MODE	BACKWASH OVERRIDE	EMERGENCY REGEN.	REGEN CYCLES	BRINE / RINSE	BACK WASH	RINSE	REGEN TIME SETTING	SALT MODE SETTING	BRINE PREFILL SET	PREFILL	Injector	Injector Color	BLFC Washer	DLFC Washer	DLFC Washer Code	
75	ENGLISH	US GALLONS	UPFLOW	1.234	DONT TOUCH	ON	0.75CF	0.2 GPM	METER DELAY	OFF	ON		90	15	15	2:00AM	STANDARD	ON	70%	#0000	Black	0.2 GPM	1.35	#7	
100	ENGLISH	US GALLONS	UPFLOW	1.234	DONT TOUCH	ON	1.0CF	0.2 GPM	METER DELAY	OFF	ON		90	15	15	2:00AM	STANDARD	ON	70%	#0000	Black	0.2 GPM	2.0	#2	
150	ENGLISH	US GALLONS	UPFLOW	1.234	DONT TOUCH	ON	1.5CF	0.2 GPM	METER DELAY	OFF	ON		90	15	15	2:00AM	STANDARD	ON	70%	#0000	Black	0.2 GPM	2.4	1S	
200	ENGLISH	US GALLONS	UPFLOW	1.234	DONT TOUCH	ON	2.0CF	0.2 GPM	METER DELAY	OFF	ON		90	15	15	2:00AM	STANDARD	ON	70%	#00	Purple	0.2 GPM	3.5	2S	
250	ENGLISH	US GALLONS	UPFLOW	1.234	DONT TOUCH	ON	2.5CF	0.2 GPM	METER DELAY	OFF	ON		90	15	15	2:00AM	STANDARD	ON	70%	#00	Purple	0.2 GPM	4.0	3S	
300	ENGLISH	US GALLONS	UPFLOW	1.234	DONT TOUCH	ON	3CF	0.2 GPM	METER DELAY	OFF	ON		90	15	15	2:00AM	STANDARD	ON	70%	#1	White	0.2 GPM	5.0	4S	

Downflow Valve Programming (Models 89DF)

PRESS '+' AND '-' FOR 8 SECONDS							PRESS MENU KEY AND SCROLL TO 'MAIN MENU'. THEN PRESS 'SET' TILL IT BEEPS. SCROLL TO ADVANCED MENU										PRESS MENU KEY AND SCROLL TO 'MAIN MENU'. THEN PRESS 'SET' TILL IT BEEPS					VALVE SETTINGS				
MODELS	LANGUAGE	REGION	VALVE	METER RATIO	SALT VS EFFICIENCY	AUTO CALCULATION	RESIN VOLUME	REFILL RATE	REGEN. MODE	BACKWASH OVERRIDE	EMERGENCY REGEN.	REGEN CYCLES	BACKWASH DURATION	BRINE DRAW DURATION	RINSE DURATION	REFILL DURATION	REGEN TIME SETTING	REGEN DAY SETTING	SYSTEM CAPACITY	SALT MODE SETTING	Injector	Injector Color	BLFC Washer	DLFC Washer	DLFC Washer Code	
75	ENGLISH	US GALLONS	DOWNFLOW	1.393	DONT TOUCH	ON	0.75CF	0.7 GPM	METER DELAY	OFF	OFF		10	60	10	N/A	2:00AM	N/A	N/A	STANDARD	#1	White	0.7 GPM	1.4	#7	
100	ENGLISH	US GALLONS	DOWNFLOW	1.393	DONT TOUCH	ON	1.0CF	0.7 GPM	METER DELAY	OFF	OFF		10	60	10	N/A	2:00AM	N/A	N/A	STANDARD	#1	White	0.7 GPM	2.0	#2	
150	ENGLISH	US GALLONS	DOWNFLOW	1.393	DONT TOUCH	ON	1.5CF	0.7 GPM	METER DELAY	OFF	OFF		10	60	10	N/A	2:00AM	N/A	N/A	STANDARD	#1	White	0.7 GPM	2.4	1S	
200	ENGLISH	US GALLONS	DOWNFLOW	1.393	DONT TOUCH	ON	2.0CF	0.7 GPM	METER DELAY	OFF	OFF		10	60	10	N/A	2:00AM	N/A	N/A	STANDARD	#2	Blue	0.7 GPM	3.5	2S	
250	ENGLISH	US GALLONS	DOWNFLOW	1.393	DONT TOUCH	ON	2.5CF	0.7 GPM	METER DELAY	OFF	OFF		10	60	10	N/A	2:00AM	N/A	N/A	STANDARD	#2	Blue	0.7 GPM	4.0	3S	
300	ENGLISH	US GALLONS	DOWNFLOW	1.393	DONT TOUCH	ON	3CF	0.7 GPM	METER DELAY	OFF	OFF		10	60	10	N/A	2:00AM	N/A	N/A	STANDARD	#3	Yellow	0.7 GPM	5.0	4S	

MASTER PROGRAMMING 89 DOWNFLOW VALVE (89 DF MODELS)

The controller will show the following on the screen - Time, Date and number of Days Remaining for Regeneration:

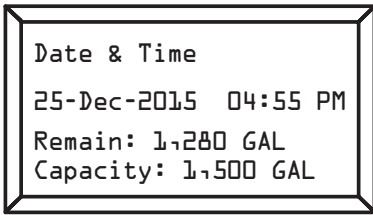

How to set Master Programming (Authorized Dealer Only)

Press "+" and "-" for 8 seconds.

Press "SET" to select and "MENU" to go back

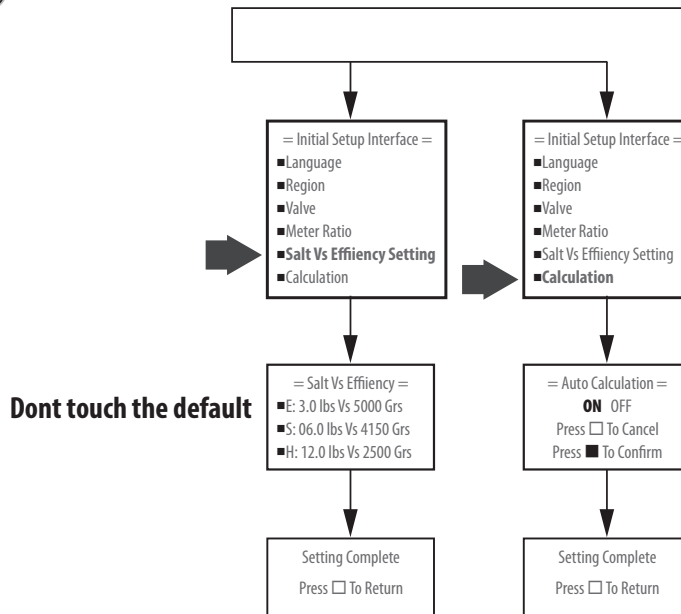
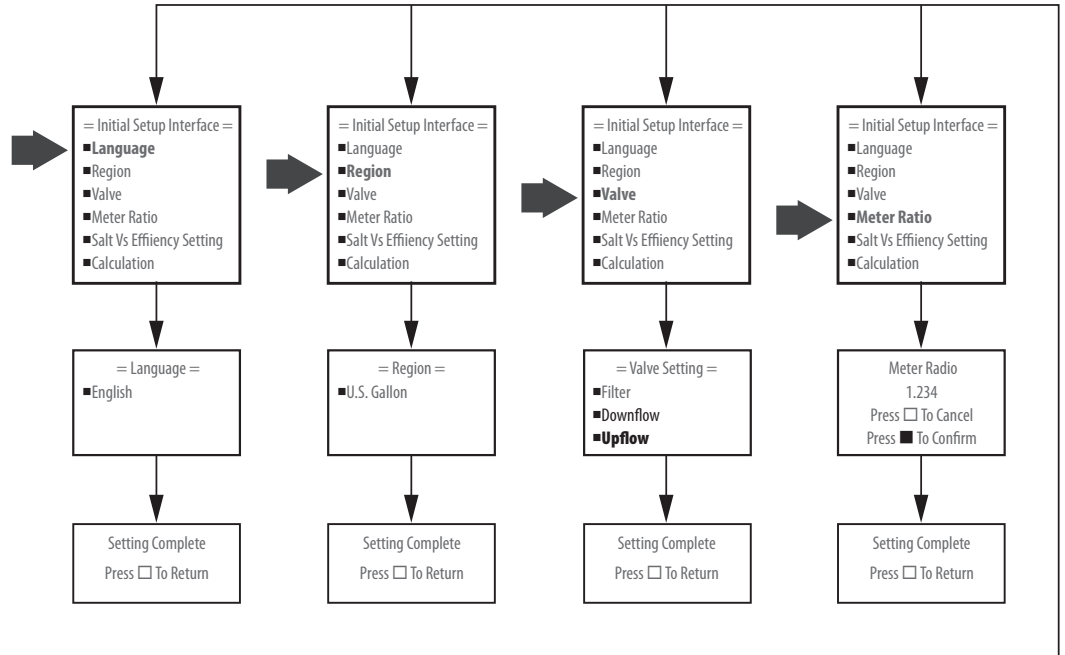

MASTER PROGRAMMING 89 UPFLOW VALVE (89UF MODELS)

The controller will show the following on the screen - Time, Date and number of Days Remaining for Regeneration:

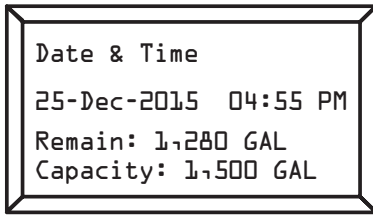

How to set Master Programming (Authorized Dealer Only)





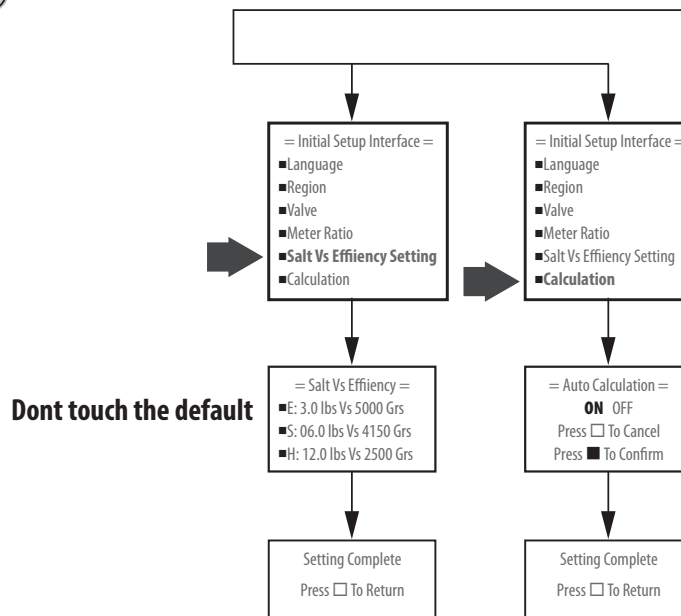
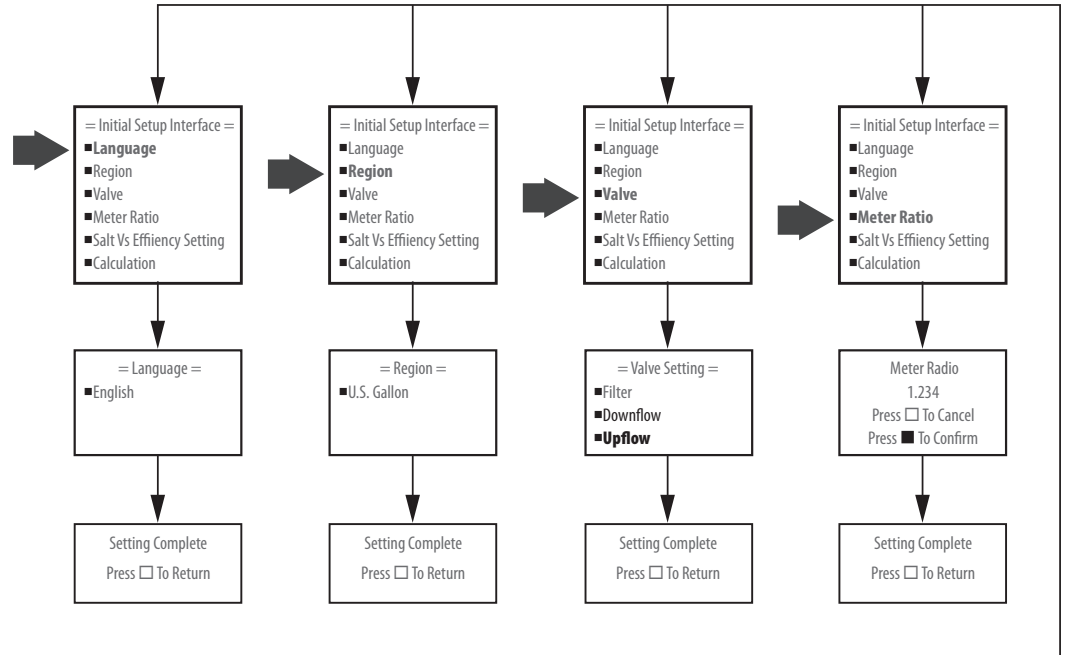



Press "+" and "-" for 8 seconds.

Press "SET" to select and "MENU" to go back



MASTER PROGRAMMING GUIDE 89 DOWNFLOW

ADVANCED MENU PRESS "MENU" KEY AND SCROLL TO "MAIN MENU". THEN PRESS "SET" TILL IT BEEPS. SCROLL TO ADVANCED MENU

Press "Menu" key . Press - to advance to Advanced Menu Press and hold "SET"  5 seconds or until you hear a beep. Press "+"  or "-"  to choose menu option.
Press "SET"  to enter. Press "+"  or "-"  to change option. Press "SET"  to accept.

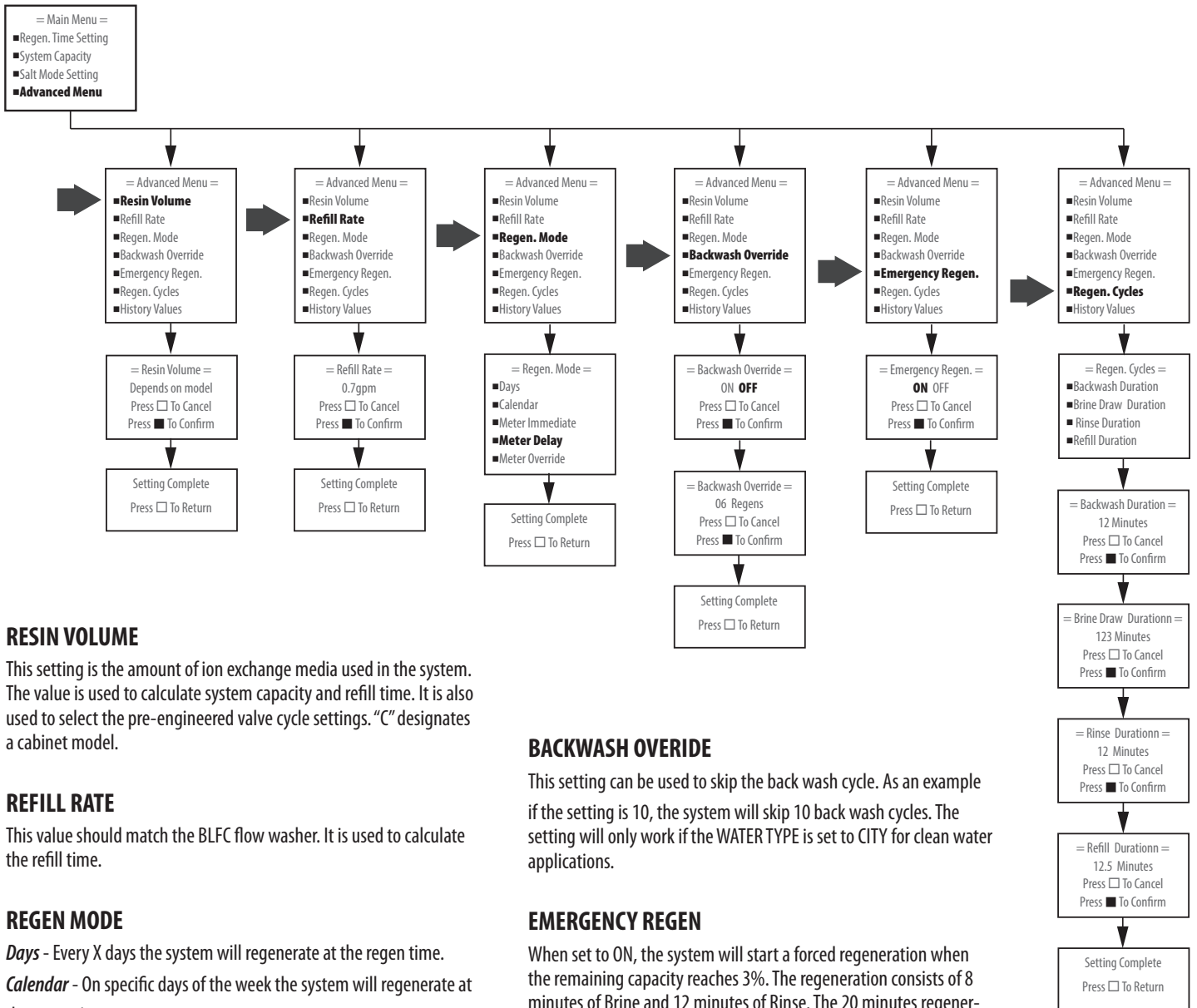

RESIN VOLUME

This setting is the amount of ion exchange media used in the system. The value is used to calculate system capacity and refill time. It is also used to select the pre-engineered valve cycle settings. "C" designates a cabinet model.

REFILL RATE

This value should match the BLFC flow washer. It is used to calculate the refill time.

REGEN MODE

Days - Every X days the system will regenerate at the regen time.

Calendar - On specific days of the week the system will regenerate at the regen time.

Meter Immediate - When the volume remaining reaches zero gallons the system will immediately regenerate.

Meter Delayed - When the volume remaining goes below the calculated reserve for that day the system will regenerate at the regen time.

Meter Override - When the volume remaining goes below the calculated reserve for that day the system will regenerate at the regen time or when X days has passed. Which ever occurs first.

BACKWASH OVERRIDE









This setting can be used to skip the back wash cycle. As an example if the setting is 10, the system will skip 10 back wash cycles. The setting will only work if the WATER TYPE is set to CITY for clean water applications.

EMERGENCY REGEN

When set to ON, the system will start a forced regeneration when the remaining capacity reaches 3%. The regeneration consists of 8 minutes of Brine and 12 minutes of Rinse. The 20 minutes regeneration will restore up to 33% of the system capacity. At the next regeneration time (2:00 AM), the system will automatically perform a standard regeneration to restore capacity to 100%.

ADVANCED MENU 89 UPFLOW

PRESS "MENU" KEY  AND SCROLL TO "MAIN MENU". THEN PRESS "SET"  TILL IT BEEPS. SCROLL TO ADVANCED MENU

Press "Menu" key . Press - to advance to Advanced Menu Press and hold "SET"  5 seconds or until you hear a beep. Press "+"  or "-"  to choose menu option. Press "SET"  to enter. Press "+"  or "-"  to change option. Press "SET"  to accept.

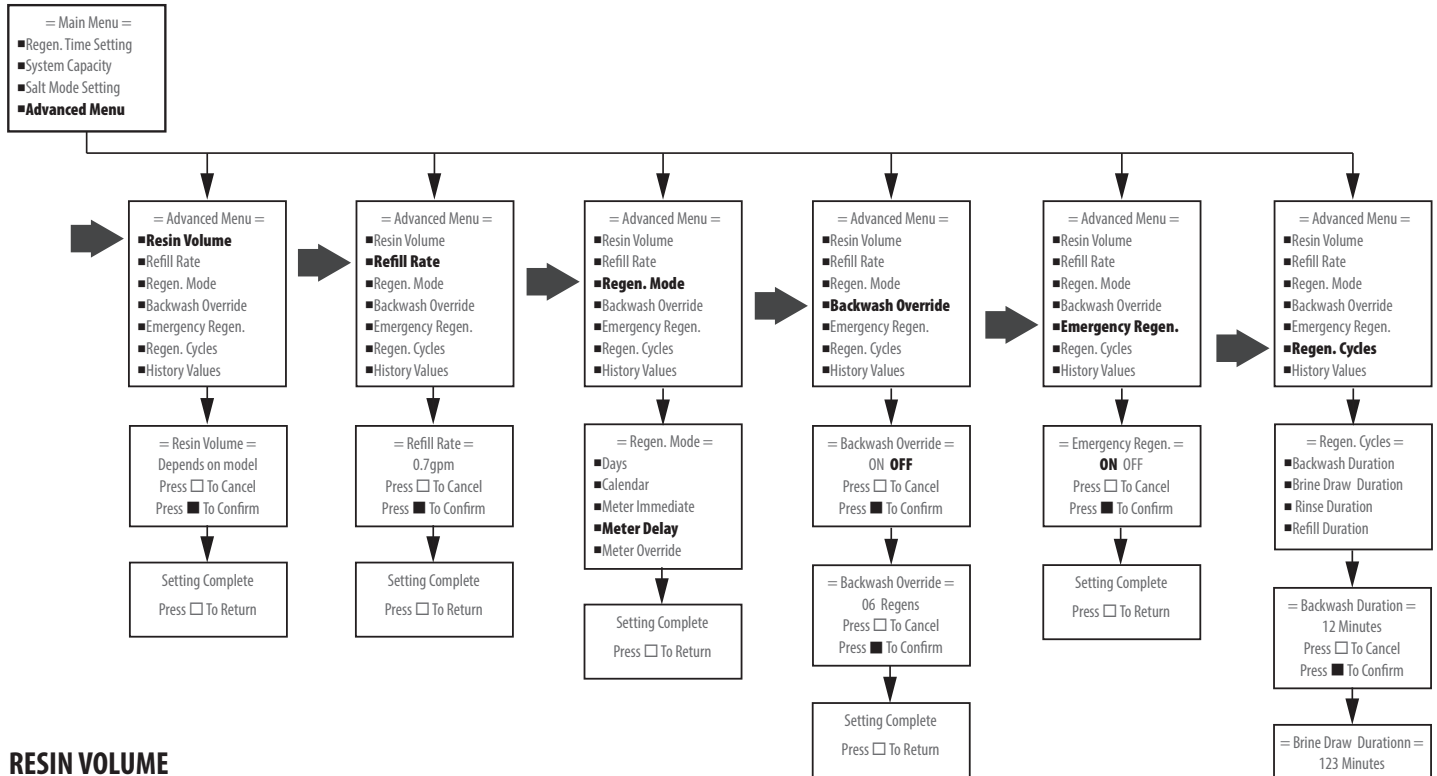

RESIN VOLUME

This setting is the amount of ion exchange media used in the system. The value is used to calculate system capacity and refill time. It is also used to select the pre-engineered valve cycle settings. "C" designates a cabinet model.

REFILL RATE

This value should match the BLFC flow washer. It is used to calculate the refill time.

REGEN MODE

Days - Every X days the system will regenerate at the regen time.

Calendar - On specific days of the week the system will regenerate at the regen time.

Meter Immediate - When the volume remaining reaches zero gallons the system will immediately regenerate.

Meter Delayed - When the volume remaining goes below the calculated reserve for that day the system will regenerate at the regen time.

Meter Override - When the volume remaining goes below the calculated reserve for that day the system will regenerate at the regen time or when X days has passed. Which ever occurs first.

BACKWASH OVERRIDE

This setting can be used to skip the back wash cycle. As an example if the setting is 10, the system will skip 10 back wash cycles. The setting will only work if the WATER TYPE is set to CITY for clean water applications.

EMERGENCY REGEN

When set to ON, the system will start a forced regeneration when the remaining capacity reaches 3%. The regeneration consists of 8 minutes of Brine and 12 minutes of Rinse. The 20 minutes regeneration will restore up to 33% of the system capacity. At the next regeneration time (2:00 AM), the system will automatically perform a standard regeneration to restore capacity to 100%.

UF SOFTENER (UP FLOW)

This mode is for the operation of an up flow regenerating softener. The regeneration sequence is 1. BRINE MAKE (REFILL), 2. BRINE, 3. BACKWASH, 4 RINSE, 5. REFILL.

MAIN MENU 89 DOWNFLOW

Press "Menu" key . Press - to advance to Advanced Menu Press and hold "SET" 5 seconds or until you hear a beep. Press "+" or "-" to choose menu option.
Press "SET" to enter. Press "+" or "-" to change option. Press "SET" to accept.

REGEN TIME

This setting determines the time of day to perform a scheduled regeneration.

SYSTEM CAPACITY

In Auto Calculation mode the system capacity is calculated. It can be manually adjusted as well.

SALT MODE SETTING

There are 3 settings to choose. Economy, Standard, and High Capacity.

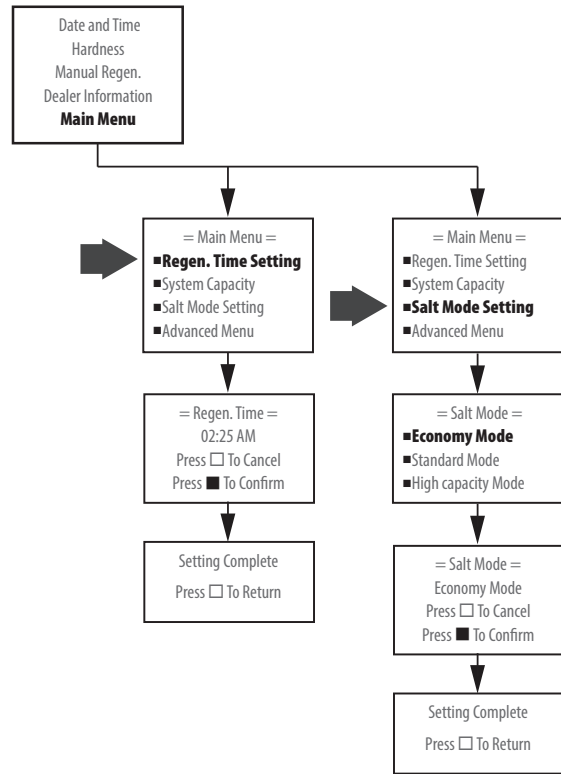

MAIN MENU 89 UPFLOW

Press "Menu" key . Press - to advance to Advanced Menu Press and hold "SET" 5 seconds or until you hear a beep. Press "+" or "-" to choose menu option.
Press "SET" to enter. Press "+" or "-" to change option. Press "SET" to accept.

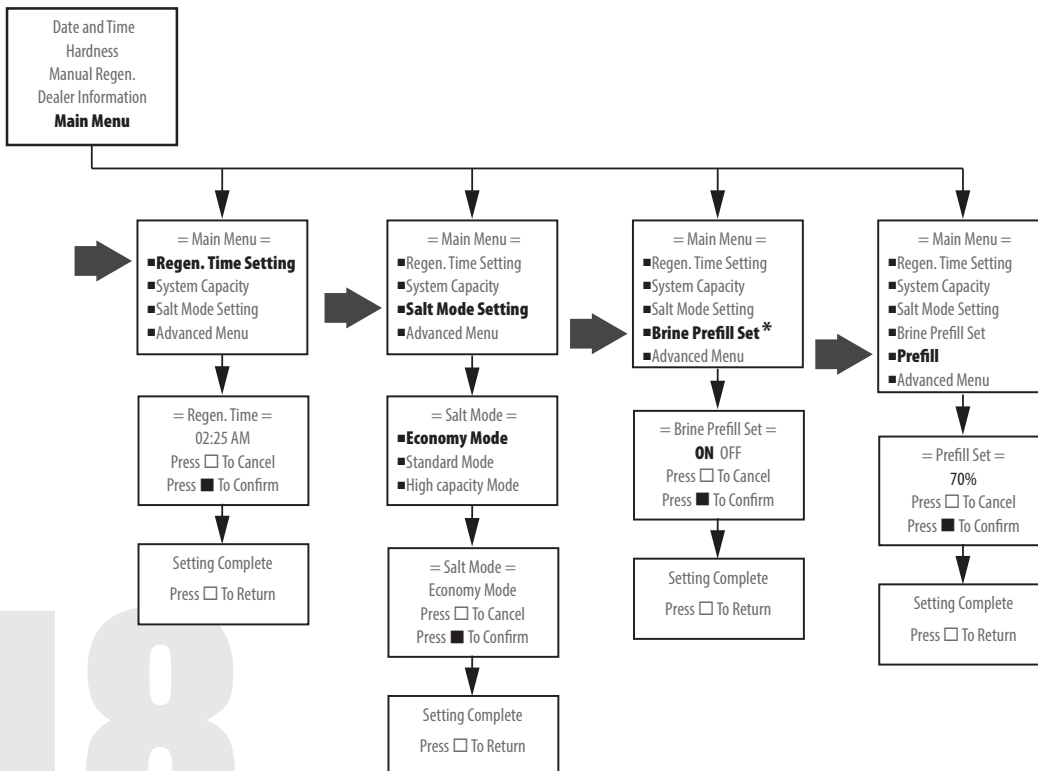

***BRINE PRE-FILL% :** This is the percentage of the water that will be added to the brine tank after a regeneration. The default is 70%. The remaining amount of water will be added just prior to the regeneration and will be proportional to the amount of capacity left in the system.

DIAGNOSTIC SCREEN

PRESS "MENU" KEY  AND SCROLL TO "MAIN MENU". THEN PRESS "SET"  TILL IT BEEPS. SCROLL TO ADVANCED MENU

Press "Menu" key . Press - to advance to Main Menu

Press "SET"  or until you hear a beep.

Press - to advance to Advanced Menu

Press and hold "SET"  5 seconds or until you hear a beep.

Press - to advance to History Values

Press "SET"  or until you hear a beep.

Press "+"  or "-"  to choose menu option. Press "SET"  to enter.

Press "+"  or "-"  to change option. Press "SET"  to accept.

PARAMETER	DESCRIPTION
LAST REGEN ON	Date of last system regeneration.
USED SINCE REGEN	Volume used since last regeneration.
CURRENT FLOW RATE	The current system flow rate.
PEAK FLOW RATE	The peak or highest flow rate since last regeneration.
SOFTWARE VERSION	The software version programmed on the PCB.
RESERVE	The calculated reserve for each day based on the highest days usage over the past 4 weeks.
28 DAYS HISTORY	The volume used for each of the last 28 days.
USAGE HISTORY	The usage since system start up and from the last reset.
TOTAL USED	The total volume used.
TOTAL REGENS	The total quantity of regenerations.
TOTAL DAYS	The total days in operation.

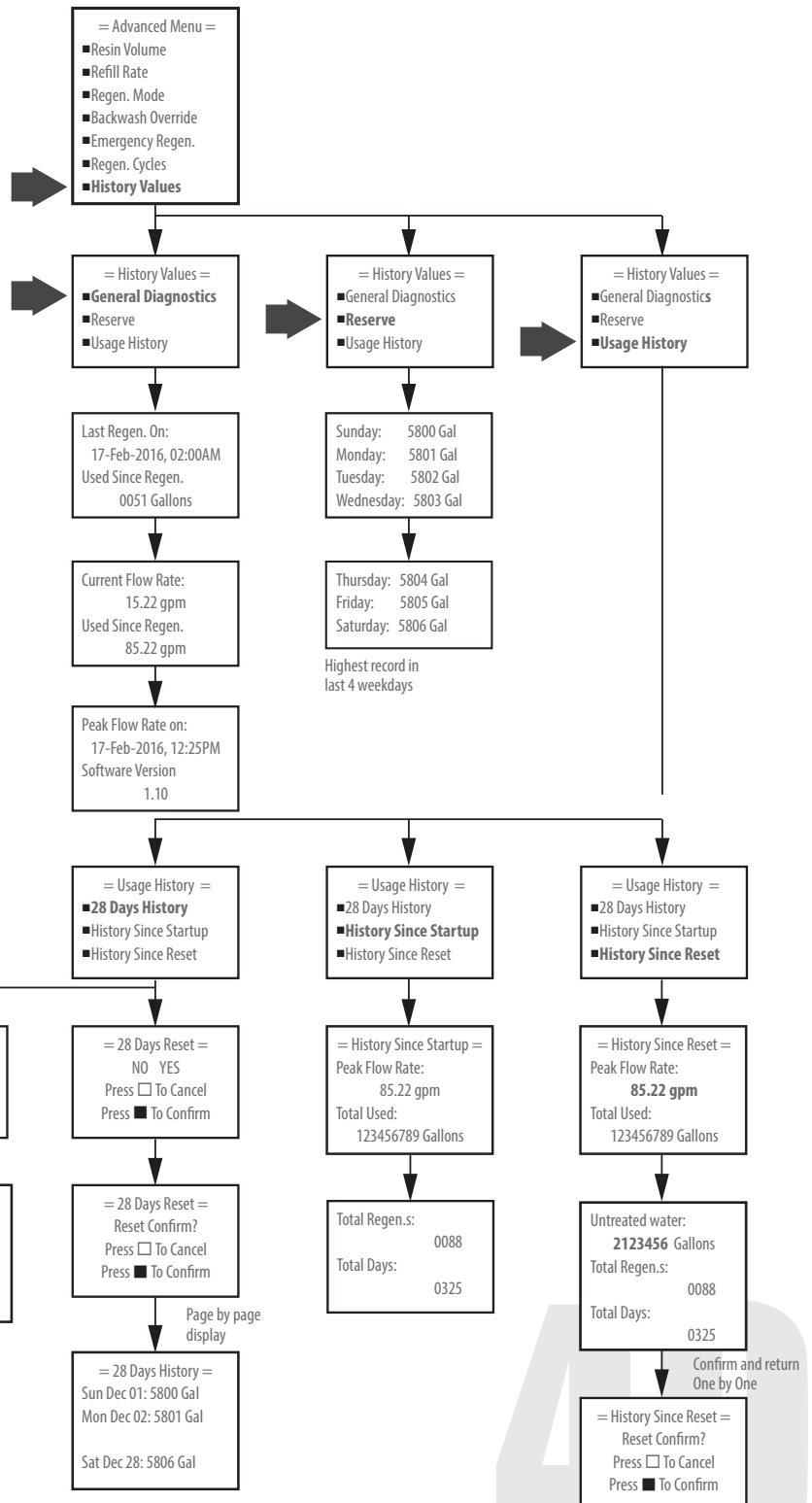

HOW TO SET DATE AND TIME AND MANUAL REGENERATION

PRESS "MENU" KEY  AND SCROLL TO "MAIN MENU". THEN PRESS "SET"  TILL IT BEEPS.

Press "Menu" key 

Press "+"  or "-"  to change menu option. Press "SET"  to enter.

Press "+"  or "-"  to change value. Press "SET"  to accept.

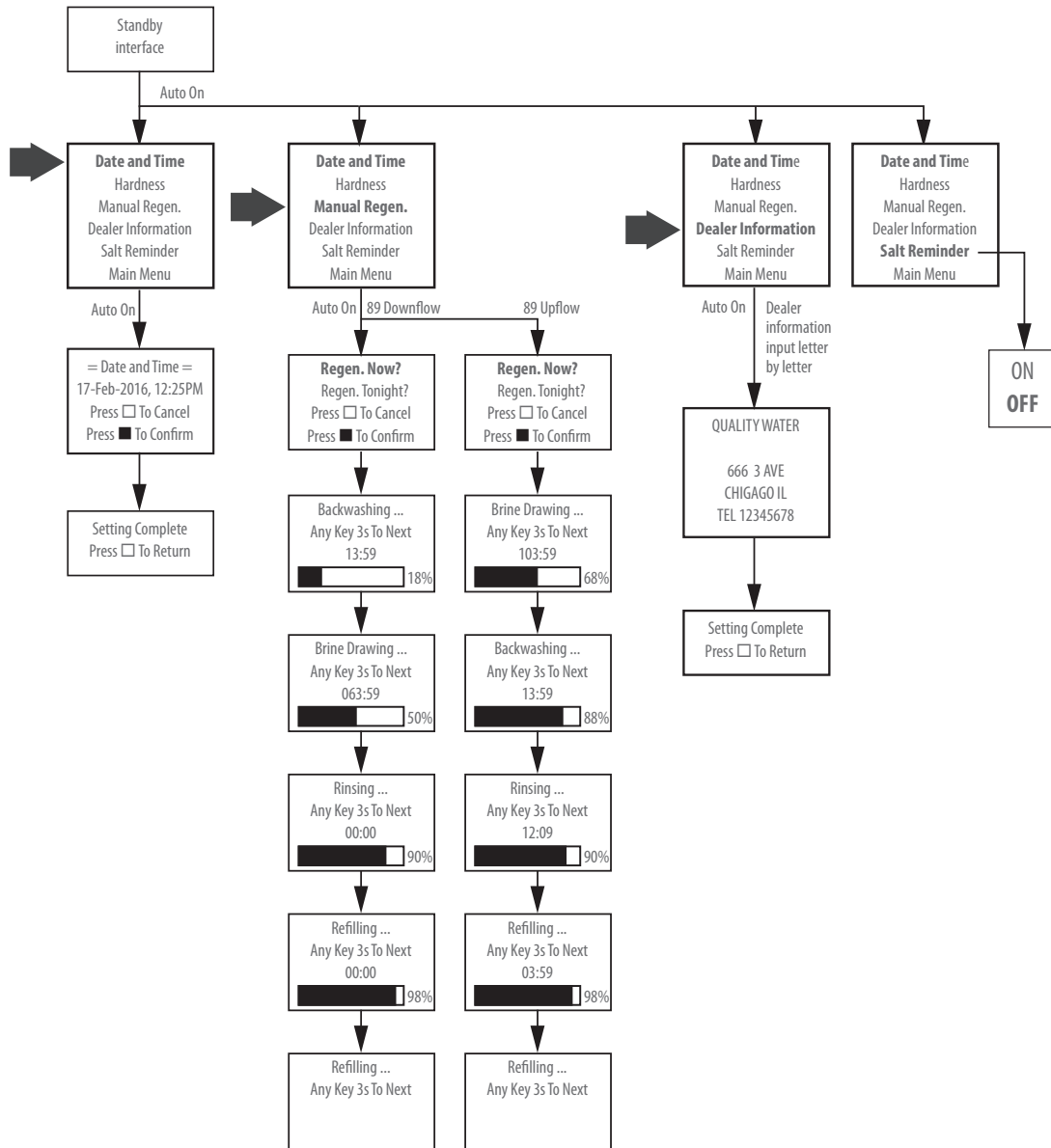

DATE AND TIME

Time of day is for normal operation of system and the scheduling of the regeneration time. The date is used in a diagnostic function to track the last time the system regenerated.

HARDNESS

This value is the maximum compensated water hardness in grains per gallon of the raw water supply. It is used to calculate the system capacity. If Ferrous Iron is present add 4 gpg for every 1 ppm of Ferrous Iron.

MANUAL REGENERATION

To start an immediate regeneration select the Manual Regen option. This setting determines the time of day to perform a scheduled regeneration. When a manual regeneration is performed on a upflow system, the total capacity may not be re-stored depending on the amount of water in the brine tank. Example if the PREFILL % is 70%, then after a manual regeneration the total capacity in gallons will be restored to 70%.

SALT REMINDER

Salt reminder can be turned ON to sound an alarm when a preset amount of salt has been used. Factory setting is 80 lbs.

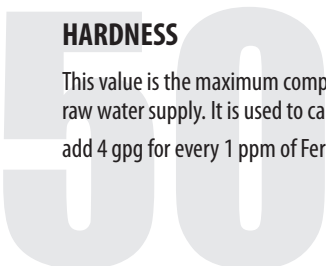

IMPORTANT WARRANTY AND MAINTENANCE INFORMATION

Please have the information below filled out and available when calling in for parts or warranty:

Model number:
Serial number:
Valve Serial number:
Date installed:

Additional notes:

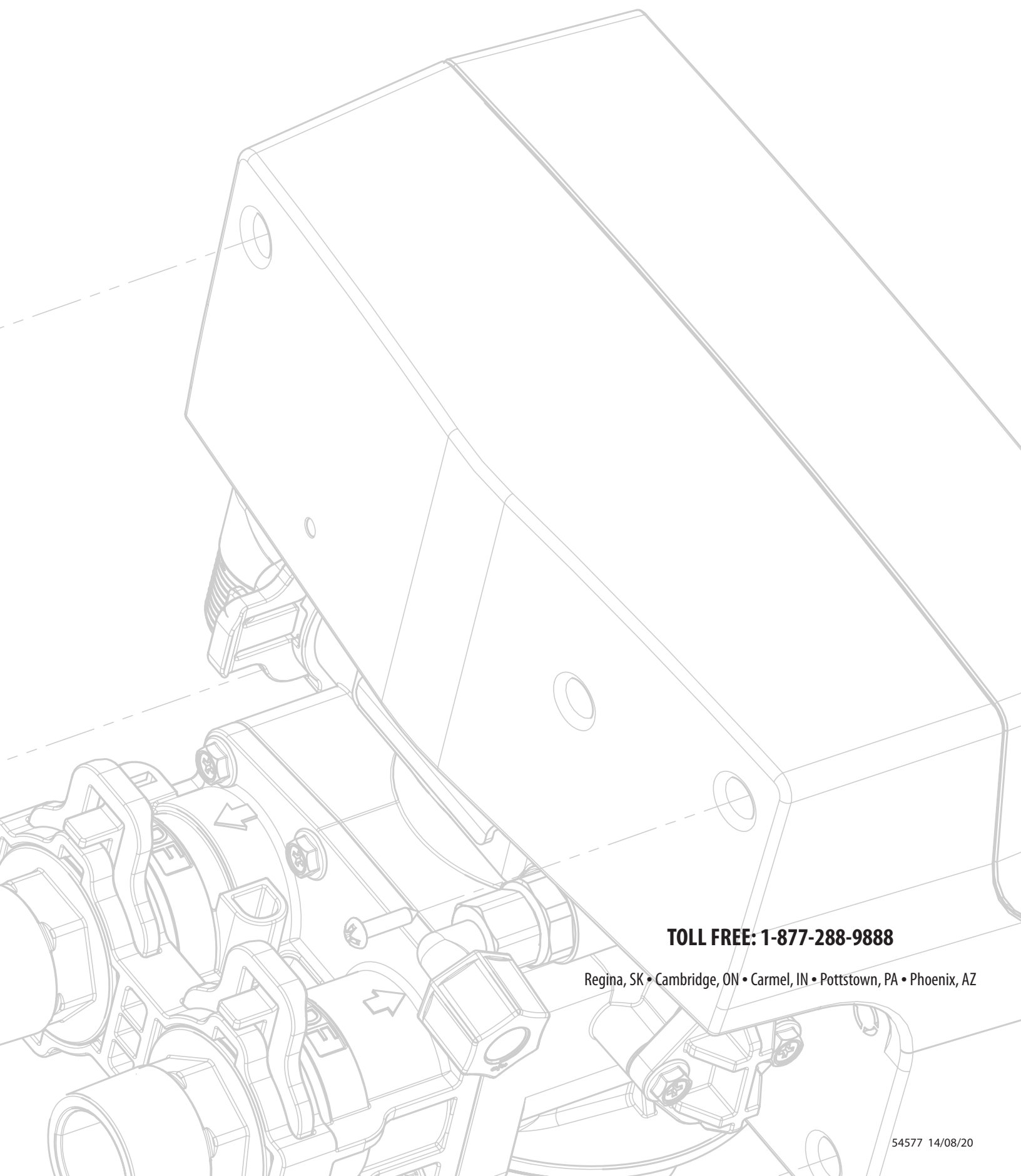

TOLL FREE: 1-877-288-9888

Regina, SK • Cambridge, ON • Carmel, IN • Pottstown, PA • Phoenix, AZ